

Metal Seated Ball Valves



Applications

KI's KV-M60 and KV-M40 Series metal seated ball valves designed for such extreme conditions as particles or hot medium can ensure the reliable control of severe operating conditions in the process control. KI's metal seated ball valve is featured by its reliable design, construction and unique abrasive technology, ensuring its bidirectional sealing. The steel ball and seat of KI's such valve is coated with suitable hard alloy to make it the right choice for the process control.

Applicability in Process Control



Refinery



Electric Power



Paper Mill



Petrochemical



Edible Oil



Other harsh conditions

Features

- Full port design, as standard, for high flow capacity and minimum turbulences.
- Double disc spring design for bidirectional sealing and a leakage class above D.
- Self-cleaning valve seat design with the scraping feature.
- Steel ball/seats set coated with hard alloy by HVOF and with the high-temperature thermal spray welding technology.
- Spring-loaded packing gland design with the self-compensation feature.
- Well-designed as inherent fire safe, anti-static property, and protection from valve stem blow out.
- Coating process design for super hardness, wear and flushing resistance.

TECHNICAL SUMMARY

Standard	ANSI / ASME	EN / DIN	JIS
Rating	ASME B16.34 Class 150 / Class 300 / Class 600 / Class 900	EN 12516-1 / DIN 3357 / EN 1983 PN10 - PN40	JIS B 2001 10K / 20K
Face to Face	ASME B16.10	EN 558	JIS B 2002 10K Form 6 JIS B 2002 20K Form 10
Connection Facing	ASME B16.5RF Serrated Finish	DIN EN 1092-1 PN10-PN40	JIS B 2220
Casting Appearance	MSS SP 55		
Inspection & Testing	API 598	EN 12266-1	JIS B 2003
Leakage Rate	ISO 5208 & EN 12266-1 Rate D or better		
Quality Assurance	ISO 9001, QS 9000, AD2000-Mertkblatt W0, PED 2014/68/EU		
Size Range	NPS ½ ~ NPS 16	DN15 - DN400	15A - 400A
Construction	Bidirectional sealing, Full port		
Typical Service	Super heated steam, Hot gas, Coal ash, Silica powder, Aluminum powder, High viscous media...etc.		
Pressure Range	Class 150 ~ Class 900	PN10 ~ PN40	JIS 10K / 20K
Temperature Range	-29°C to +538°C		
Materials	Carbon steel, Stainless steel, and duplex stainless steel, etc...		
End connections	Flanged		
Operation	Lever or gear operated, Pneumatic or electric actuated		

AVAILABLE OPTIONS:

- Castings per NACE Standard MR 0175 for Sour Gas Service
- Inspection Certificate according to EN 10204 3.2 Form
- Inspection Testing per API 6D

Casted Metal Seated Ball Valves

For Temperature Up to 450°C / 842°F

DESIGN FEATURES

Positioning/Locking Bracket Design

It can better support and stabilize the actuator to ensure reliable valve operation.

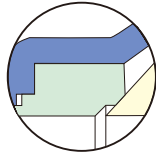

Scratch Seat Design

Enable to Remove Slurries, Muds or Other Viscous Fluids & Solid Mediums
Special Hardened Surface Treatment :
Stainless Steel Cr3C2/WC-Co/
Stellite 2.0 /Ni60...etc.



Double Disc Spring/Plunger Spring Design

Such design realizes the bidirectional sealing of the valve. It provides the elasticity helpful to absorb the tube stress and thermal expansion and to avoid a jammed valve. On the other hand, the bidirectional seated ball valve is more advantageous than the unidirectional one under certain operating conditions with the reverse sealing requirement.



Ball

Hardened Surface Treatment
Stainless + Cr3C2/WC-Co/
Stellite.20/Ni60...etc.
For High Temperature,
Abrasive Services

Such Construction Design as Expanded Sealing Surface on the Valve Seal

More beneficial to the ball/seat sealing and elongating the switch service life.

Drain Design

For Easy
Cleaning on
Pipelines

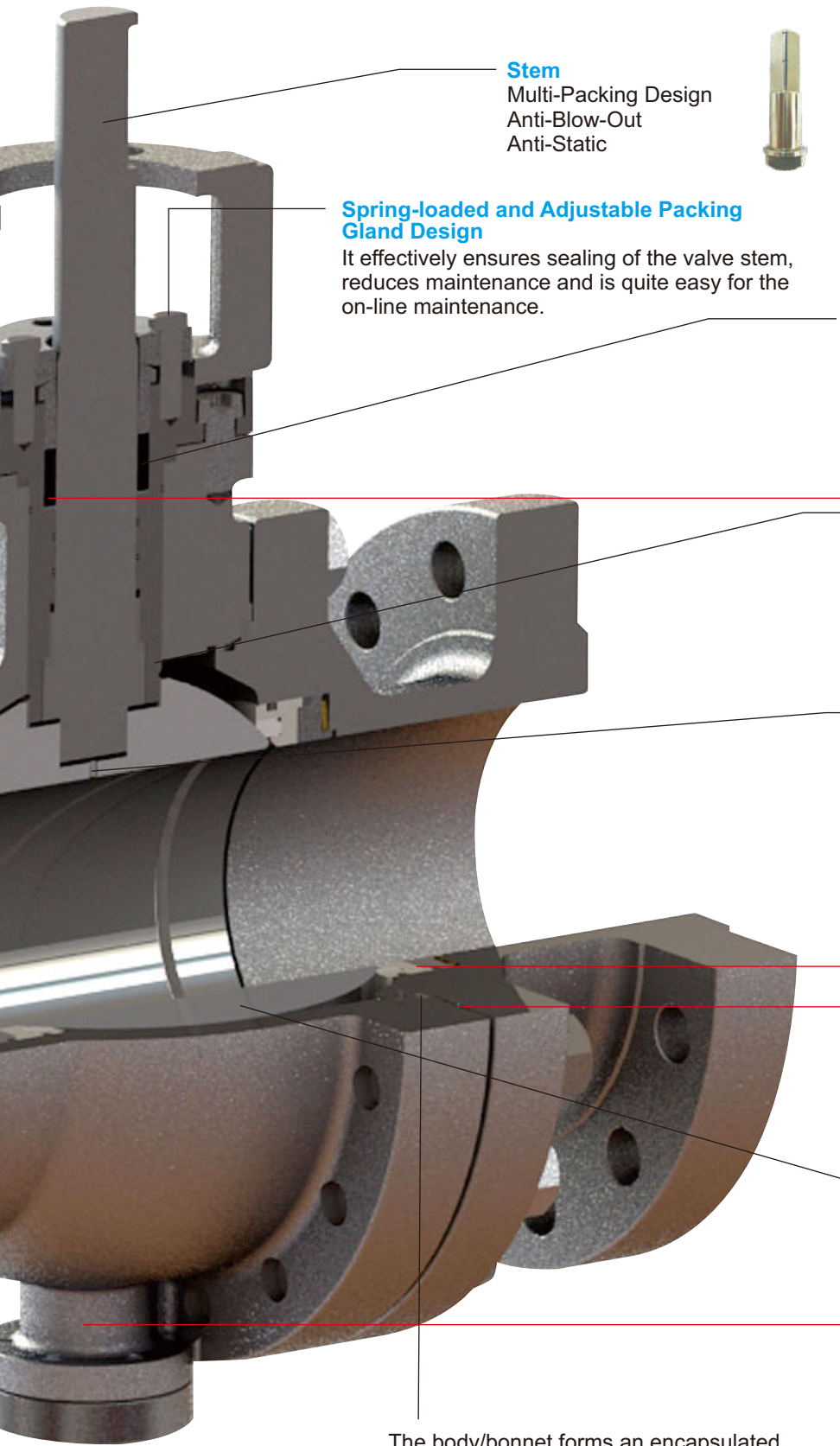

Stem
Multi-Packing Design
Anti-Blow-Out
Anti-Static



Spring-loaded and Adjustable Packing Gland Design
It effectively ensures sealing of the valve stem, reduces maintenance and is quite easy for the on-line maintenance.



Flexible Graphite Stem Packing For Severe Services
It is suitable for services under extreme operating conditions. ISO 15848-1 low emission test certified packing is available upon request.

The mid flange and bottom end cap of the trunnion type ball valves form a stationary rotation system, in which the valve stem bears the torque other than the medium thrust, thus significantly elongating the service life of the valve stem.

Steel Ball Pressure Balancing Hole Design
When the valve is "ON", the pressure balance is realized between the valve chamber and channel to ensure safer and more reliable valve operation.

Fire Safe Design Approved

According to ISO 10497 3rd edition

The ball/seats are ground with the CNC ball grinding machine. The lapping equipment independently developed by KI is also adopted. The ball/seat roundness is about 5 um. This is a crucial technology for ensuring the standard-compliant inner leakage. The ball/seats interchangeability is high. Such accessory as ball/seat needs replacing upon demand, other than the overall valve.

The body/bonnet forms an encapsulated groove, ensuring the sealing property of the gasket and avoiding medium leakage.

Forged Metal Seated Ball Valves

For Temperature Up to 538°C/ 1000°F

DESIGN FEATURES

High Tensile Handle Design

It avoids insufficient "ON/OFF" operations due to the handle deformation.

High Tensile Stem Material Design

Such safety design as blow-out prevention and stem extension ensure excellent service of the valve at hot and high-pressure atmosphere.

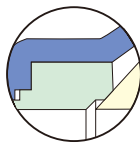

Scratch Seat Design

Enable to Remove Slurries, Muds or Other Viscous Fluids & Solid Mediums
Special Hardened Surface Treatment :
Stainless Steel Cr3C2/WC-Co/
Stellite 2.0 /Ni60...etc.

Low-torque Disc Spring Design

Strict design and inspection ensure the minimum preload of the valve and reduce its torque.

The ball/seats are ground with the CNC ball grinding machine. The lapping equipment independently developed by KI is also adopted. The ball/seat roundness is about 5 um. This is a crucial technology for ensuring the standard-compliant inner leakage. The ball/seats interchangeability is high. Such accessory as ball/seat needs replacing upon demand, other than the overall valve.

Spring-loaded and Adjustable Packing Gland Design

It effectively ensures sealing of the valve stem, reduces maintenance and is quite easy for the on-line maintenance.



Flexible Graphite Stem Packing For Severe Services

It is suitable for services under extreme operating conditions. ISO 15848-1 low emission test certified packing is available upon request .

Rigid Extension Bracket Design

It elongates the service life of the flexible graphite packing, reduces the temperature in the operation position at a high temperature, and ensures the user-friendly operation.

Metal Wear-resistant Bearing Design

It ensures the reliable rotation on the central shaft.

Ball

Hardened Surface Treatment
Stainless + Cr3C2/WC-Co/
Stellite.20/Ni60...etc.
For High Temperature,
Abrasive Services

The body/bonnet forms an encapsulated groove, ensuring the sealing property of the gasket and avoiding medium leakage.



DESIGN FEATURES

API 608 Compliance Stop Plate (Locking Plate)

The Position Stop is independent of the packing gland construction. It allows the valve to be locked in both the fully open and closed position by a lockable device with an 8mm padlock.

Spring-loaded and Adjustable Packing Gland Design

It effectively ensures sealing of the valve stem, reduces maintenance and is quite easy for the on-line maintenance.

Scratch Seat Design

Enable to Remove Slurries, Muds or Other Viscous Fluids & Solid Mediums Special Hardened Surface Treatment :
Stainless Steel Cr3C2/WC-Co/
Stellite 2.0 /Ni60...etc.

Flexible Graphite Stem Packing For Severe Services

It is suitable for services under extreme operating conditions. ISO 15848-1 low emission test certified packing is available upon request.

Low-torque Disc Spring Designs

Strict design and inspection ensure the minimum preload of the valve and reduce its torque.

Ball

Hardened Surface Treatment
Stainless + Cr3C2/WC-Co/
Stellite.20/Ni60...etc.
For High Temperature,
Abrasive Services

The ball/seats are ground with the CNC ball grinding machine. The lapping equipment independently developed by KI is also adopted. The ball/seat roundness is about 5 um. This is a crucial technology for ensuring the standard-compliant inner leakage. The ball/seats interchangeability is high. Such accessory as ball/seat needs replacing upon demand, other than the overall valve.

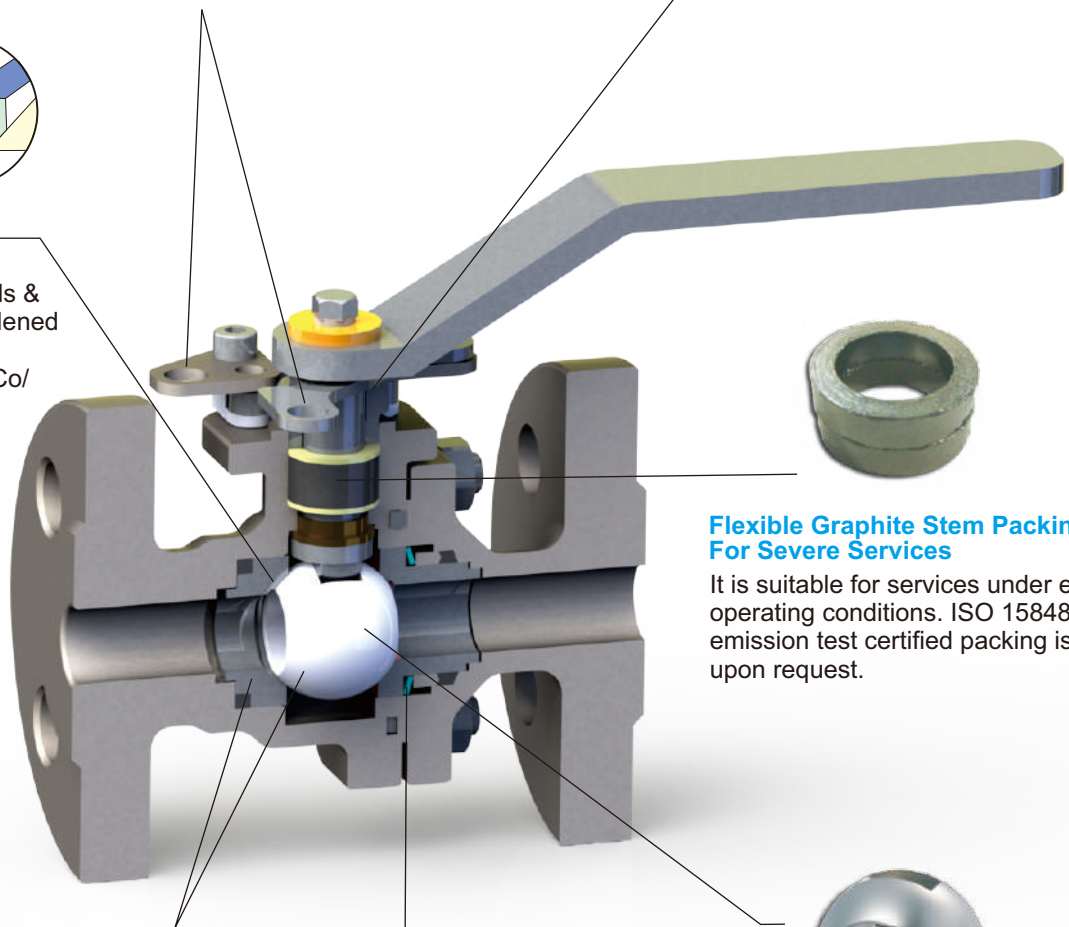
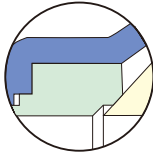

HVOF SYSTEM

- High binding strength of the coating and substrate
- Coating hardness, low porosity
- Low temperature, residual stress is small
- High binding strength of the coating and substrate

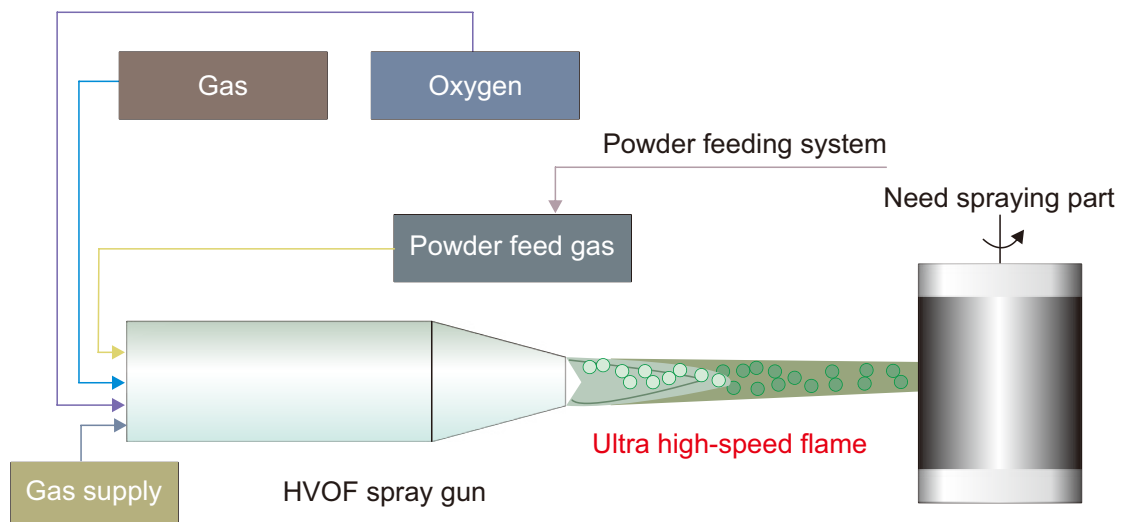

ADVANCED TESTING EQUIPMENT



CMM



Hardness Tester

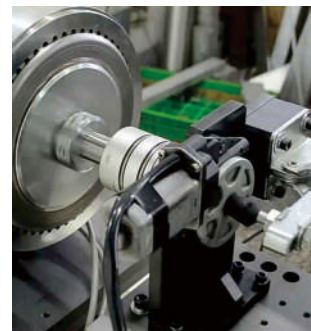

Multi-Torsion Testing



Spectrometer



Helium Leak Detectors



Roundness Testing Instrument

HVOF BRIEF INTRODUCTION

Selecting a suitable surface hardening treatment technology for the metal seated ball valve is critical to overcoming harsh operating conditions. In addition to the sealing property, such surface must resist wear and corrosion. The surface hardening process must conform to the accurate substrate adhesion, corrosion resistance and thermal stability. Different surface treatment methods are adopted for the outer layer surface of new surface coating material.

COATING MATERIALS AND PROCESSES

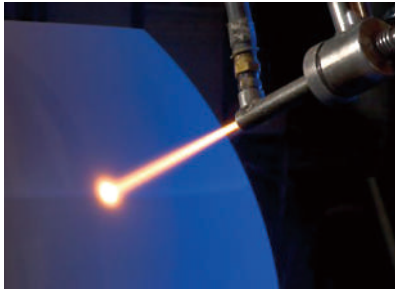

Cr3C2

Chromium carbide (Cr3C2) coating is applicable to HVOF, with the coating thickness up to 0.3 mm. If Cr3C2 coating is applied onto the high tensile steel, its hardness will be up to 59HRC. Such coating is applicable at a temperature as high as 815°C. The maximum operating temperature of the valve is 538°C. This multipurpose wear resistance coating is used extensively in the power generation, refining and hot catalyst handling services. Its limitations are in wet sulphur or chloride environments where sulphuric acid can form and attack the coating.

WC-Co

Tungsten Carbide (WC-Co) coating is applied by HVOF technology similar to Cr3C2. WC-Co coating applied mainly to 300 series austenitic stainless steel and 400 series martensitic stainless steel results with micro-hardness as high as 68HRC. This coating is applicable to the valve operating at 400°C. In particular, the combination of WC-Co and martensitic stainless steel offers better effects. WC-Co is a wear resistance and dense coating with chemical resistance to sulphur environment on Nickel based alloy.

Stellite.20

Cobalt-chromium-tungsten Alloy 20 coating offers the excellent mechanical wear resistance and good corrosion resistance. The operating temperature is up to 538°C (1000°F). Stellite. 20 coating technology is similar to Cr3C2 and adopts HVOF. Stellite. 20 is broadly used in the pulp and paper industry, as well as in refining applications, such as catalyst handling process.



High Velocity Oxygen Fuel (HVOF) is to generate the supersonic flame air flow (the temperature is up to 3000°C, and the velocity ranges between 1400 ~1700m/s) by utilizing the high temperature and pressure in the combustion chamber where such combustible gas as propane is combusted. Driven by the high velocity flame air flow, the hard alloy powder moves at high speed and then is sprayed onto the workpiece. The coating formed in this way has such benefits as low porosity (Type A porosity<1%), high bonding strength (>70Mpa, MAX. 83Mpa), high hardness (up to HRC75), low residual stress, and good surface finish. Moreover, in case of supersonic coating, the substrate does not need heating at a high temperature, thus ensuring no deformation of the substrate.

The high-temperature thermal coating is to heat the substrate during thermal coating, so the coating is melt on the substrate surface and forms a melt layer on the hard alloy surface. Such coating formed like this is not purely a covering coating, but a co-melt layer of metal and the substrate. Its bonding strength is high (up to 400 Mpa). The hard alloy powder moves at high speed and then is sprayed onto the workpiece.

Ni60 (Powder Flame Spraying)

Nickel based alloy (Ni60) is applied by the high-temperature thermal spray welding technology. The substrate is heated during spray welding, so that Ni60 coating is melt on the substrate surface. Its bonding strength is high. The maximum operating temperature of such coating is 815 °C, while the maximum operating temperature of the valve is 538 °C. The hardness of the spray welded coating is up to 63HRC. Such coating is applicable at corrosion and wear-resistant environments.

● Hardness Value on Ball & Seat Surfaces

Coating Type	Coating Hardness		Temperature Limit		Chemical Composition	Thickness (mm)	Binding force	Coating Method	Description
	HV	HRC	°F	°C					
Tungsten Carbide (WC-Co)	780~950	65 +/-3	752	400	88%WC-12% Co	0.2 ~ 0.3	Mechanical Bonding	HVOF Spray	Excellent anti-wear properties under lower temperature. Suitable for media with dust or particle.
Nickel Alloy (Ni60)	680~780	60 +/-3	1202	650	15.5%Cr 0.8%C 4.7%Fe 4.3%Si Bal Ni	0.8 ~ 1.0	Fusion Welding Bonding	Flame Spraying	Excellent resistance to corrosion and abrasion. Suitable for protection against abrasion and erosion.
Chrome Carbide (Cr3C2-NiCr)	560~680	56 +/-3	1598	870	75%Cr3C2 25%NiCr	0.2 ~ 0.3	Mechanical Bonding	HVOF Spray	Excellent resistance to cavitation erosion under high temperature and sliding wear. Suitable for high temperature, high pressure and corrosive application.
STL.20	490~590	52 +/-3	1000	538	2.45%C 3.25%Cr 1%Si 17.5%W 3%Fe	0.2 ~ 0.3	Mechanical Bonding	HVOF Spray	Cobalt-chromium-tungsten Alloy 20 coating offers the excellent mechanical wear resistance and good corrosion resistance. It is broadly used in the pulp and paper industry, as well as in refining applications, such as catalyst handling process.

* Special coating can be ordered according to the user's requirements

● INDEX

Model No.	Pressure Rating	Size Range		Temperature Range	
		Floating Type	Trunnion Type		
ANSI/ASME	KV-M41	ASME Class 150	NPS 1/2 ~ NPS 3	NPS 4 ~ NPS 16	-29°C ~ 200°C (-20.2°F ~ 392°F)
	KV-M61	ASME Class 150	NPS 1/2 ~ NPS 3	NPS 4 ~ NPS 16	-29°C ~ 450°C (-20.2°F ~ 842°F)
	KV-M42	ASME Class 300	NPS 1/2 ~ NPS 3	NPS 4 ~ NPS 16	-29°C ~ 200°C (-20.2°F ~ 392°F)
	KV-M62	ASME Class 300	NPS 1/2 ~ NPS 3	NPS 4 ~ NPS 16	-29°C ~ 450°C (-20.2°F ~ 842°F)
	KV-M43	ASME Class 600	NPS 1/2 ~ NPS 1 1/2	NPS 2 ~ NPS 16	-29°C ~ 200°C (-20.2°F ~ 392°F)
	KV-M63	ASME Class 600	NPS 1/2 ~ NPS 1 1/2	NPS 2 ~ NPS 16	-29°C ~ 400°C (-20.2°F ~ 752°F)
	KV-M45	ASME Class 900	NPS 1/2 ~ NPS 1 1/2	NPS 2 ~ NPS 16	-29°C ~ 200°C (-20.2°F ~ 392°F)
	KV-M65	ASME Class 900	NPS 1/2 ~ NPS 1 1/2	NPS 2 ~ NPS 16	-29°C ~ 400°C (-20.2°F ~ 752°F)
	KV-M63-HF	ASME Class 600	NPS 1/2 ~ NPS 3	NPS 4 ~ NPS 10	-29°C ~ 538°C (-20.2°F ~ 1000°F)
	KV-M65-HF	ASME Class 900	NPS 1/2 ~ NPS 3	NPS 4 ~ NPS 10	-29°C ~ 538°C (-20.2°F ~ 1000°F)
EN/DIN	KV-M4J	DIN PN10	DN15~DN80	DN100~DN300	-29°C ~ 200°C (-20.2°F ~ 392°F)
	KV-M6J	DIN PN10	DN15~DN80	DN100~DN300	-29°C ~ 450°C (-20.2°F ~ 842°F)
	KV-M4K	DIN PN16	DN15~DN80	DN100~DN300	-29°C ~ 200°C (-20.2°F ~ 392°F)
	KV-M6K	DIN PN16	DN15~DN80	DN100~DN300	-29°C ~ 450°C (-20.2°F ~ 842°F)
	KV-M4M	DIN PN25	DN15~DN80	DN100~DN300	-29°C ~ 200°C (-20.2°F ~ 392°F)
	KV-M6M	DIN PN25	DN15~DN80	DN100~DN300	-29°C ~ 450°C (-20.2°F ~ 842°F)
	KV-M4N	DIN PN40	DN15~DN80	DN100~DN300	-29°C ~ 200°C (-20.2°F ~ 392°F)
	KV-M6N	DIN PN40	DN15~DN80	DN100~DN300	-29°C ~ 450°C (-20.2°F ~ 842°F)
	KV-M64J-F27	DIN PN10	DN15~DN100	DN150	-29°C ~ 400°C (-20.2°F ~ 752°F)
	KV-M64K-F27	DIN PN16	DN15~DN100	DN150	-29°C ~ 400°C (-20.2°F ~ 752°F)
	KV-M64M-F27	DIN PN25	DN15~DN100	DN150	-29°C ~ 400°C (-20.2°F ~ 752°F)
	KV-M64N-F27	DIN PN40	DN15~DN100	DN150	-29°C ~ 400°C (-20.2°F ~ 752°F)
	JIS	KV-M4A	JIS 10K	15A~80A	100A~300A
KV-M6A		JIS 10K	15A~80A	100A~300A	-29°C ~ 450°C (-20.2°F ~ 842°F)
KV-M4C		JIS 20K	15A~80A	100A~300A	-29°C ~ 200°C (-20.2°F ~ 392°F)
KV-M6C		JIS 20K	15A~80A	100A~300A	-29°C ~ 450°C (-20.2°F ~ 842°F)

Floating Type

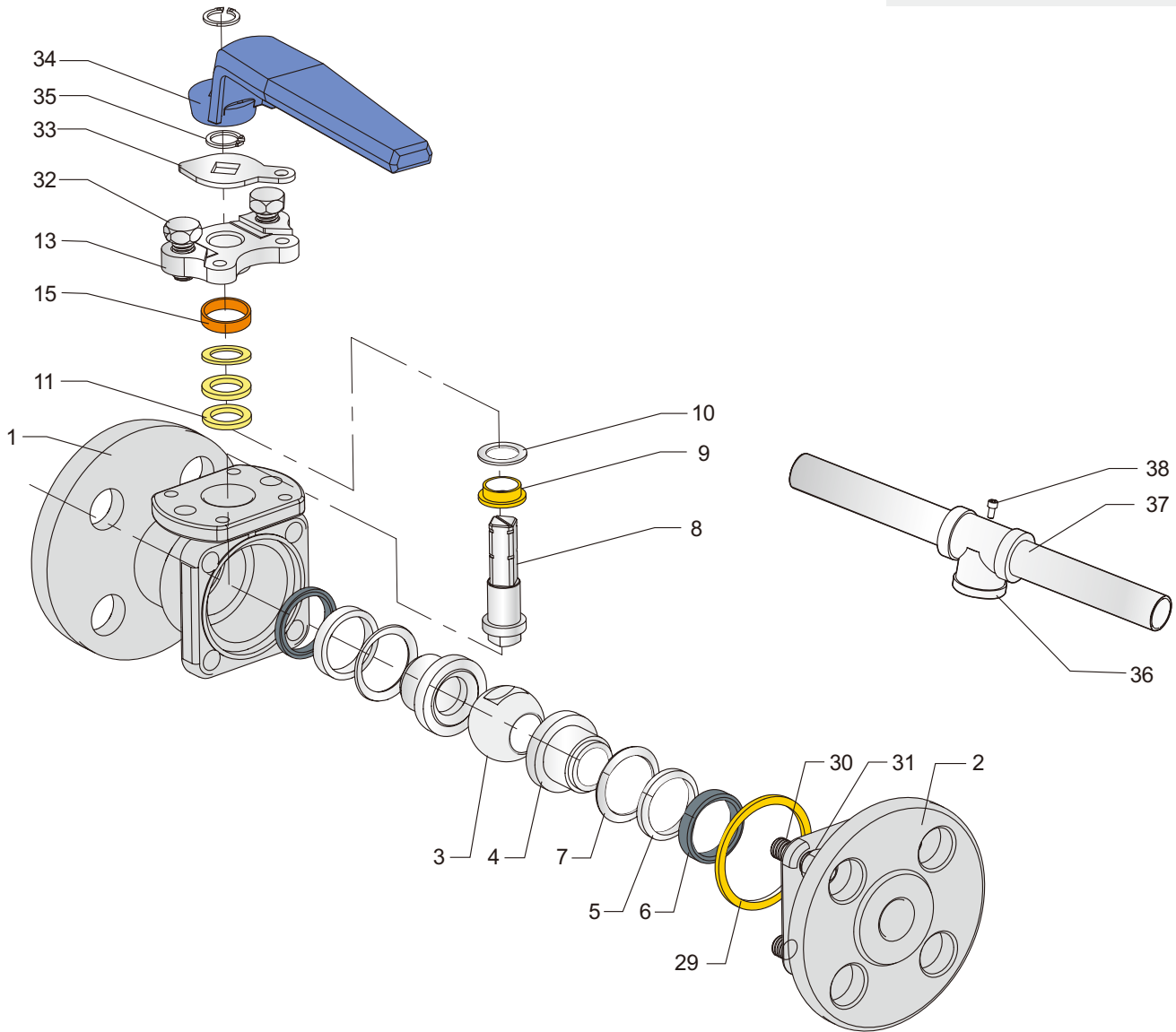

NO	PART NAME	MATERIALS			
1	Body	A351-CF8M	A351-CF8	A216-WCB	Other Alloy Steel
2	Body end	A351-CF8M	A351-CF8	A216-WCB	Other Alloy Steel
3	Ball	A182-F316+Cemented Carbide		A182-F304+Cemented Carbide	
4	Seat	A182-F316+Cemented Carbide		A182-F304+Cemented Carbide	
5	Pressure ring	A182-F316		A182-F304	
6	Seal ring	GRAPHITE			
7	Belleville spring	INCONEL X-750 * / SUS631			SUS631
8	Stem	ASTM A564 630			
9	Stem sleeve	A439 D2*/50%SS+50%PTFE			
10	Packing bushing	SUS316			
11	Stem packing	GRAPHITE* /PTFE			
12	Gland	A351-CF8		A216-WCB	
13	Packing gland	A351-CF8		A216-WCB	
14	Hexagon bolt	A193-B8		A193-B7	
15	Wear sleeve	A439 D2*/50%SS+50%PTFE			
16	Mid. Flange gasket	316 SPIRAL WOUND+GRAPHITE*/PTFE		304 SPIRAL WOUND+GRAPHITE*/PTFE	
17	Mid. Flange	A351-CF8M		A351-CF8	
18	Hexagon socket cap head screw	A193-B8		A193-B7	
19	Fully threaded stud	A193-B8		A193-B7	
20	Hexagon nut	A194-8		A194-2H	

* Materials For Fire Safe Type

Trunnion Type

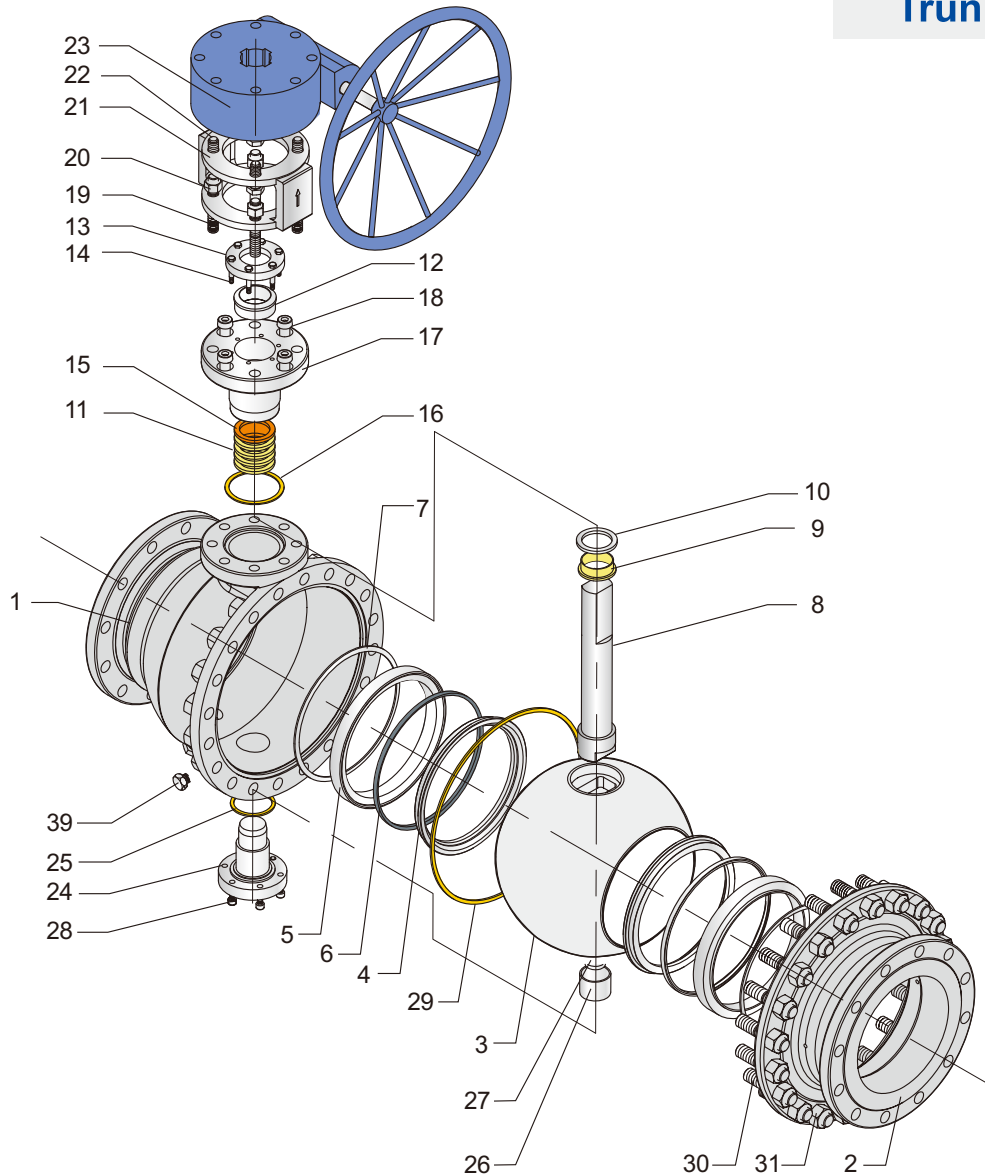

NO	PART NAME	MATERIALS			
21	Yoke	ASTM A216-WCB			
22	Hexagon bolt	A193-B8		A193-B7	
23	Worm gear	Assembly			
24	Bottom end cap	A182-F316	A182-F304		ASTM A105
25	Bottom end cap seal ring	316 SPIRAL WOUND+GRAPHITE*/PTFE		304 SPIRAL WOUND+GRAPHITE*/PTFE	
26	Bottom end cap sleeve	A439 D2*/50%SS+50%PTFE			
27	Bottom end cap wear bushing	A439 D2*/50%SS+50%PTFE			
28	Hexagon socket cap head screw	A193-B8		A193-B7	
29	Body gasket	316 SPIRAL WOUND+GRAPHITE*/PTFE		304 SPIRAL WOUND+GRAPHITE*/PTFE	
30	Stud	A193-B8		A193-B7	
31	Hexagon nut	A194-8		A194-2H	
32	Hexagon bolt	A193-B8		A193-B7	
33	Stopper locking	304			
34	Handle	A216-WCB			
35	Retainer ring	304			
36	Handle connector	A351-CF8		A216-WCB	
37	Steel tube handle	A53+Zn Plated			
38	Set screw	A2-70			
39	Drain plug	A351-CF8M	A351-CF8	A105	Other Alloy Steel

**ASME Class 150/300
2-PC Body, Flanged Ends, Full Port**

KV-M41, KV-M42 (-29 °C ~ 200 °C)
KV-M61, KV-M62 (-29 °C ~ 450 °C) (Fire Safe Type)

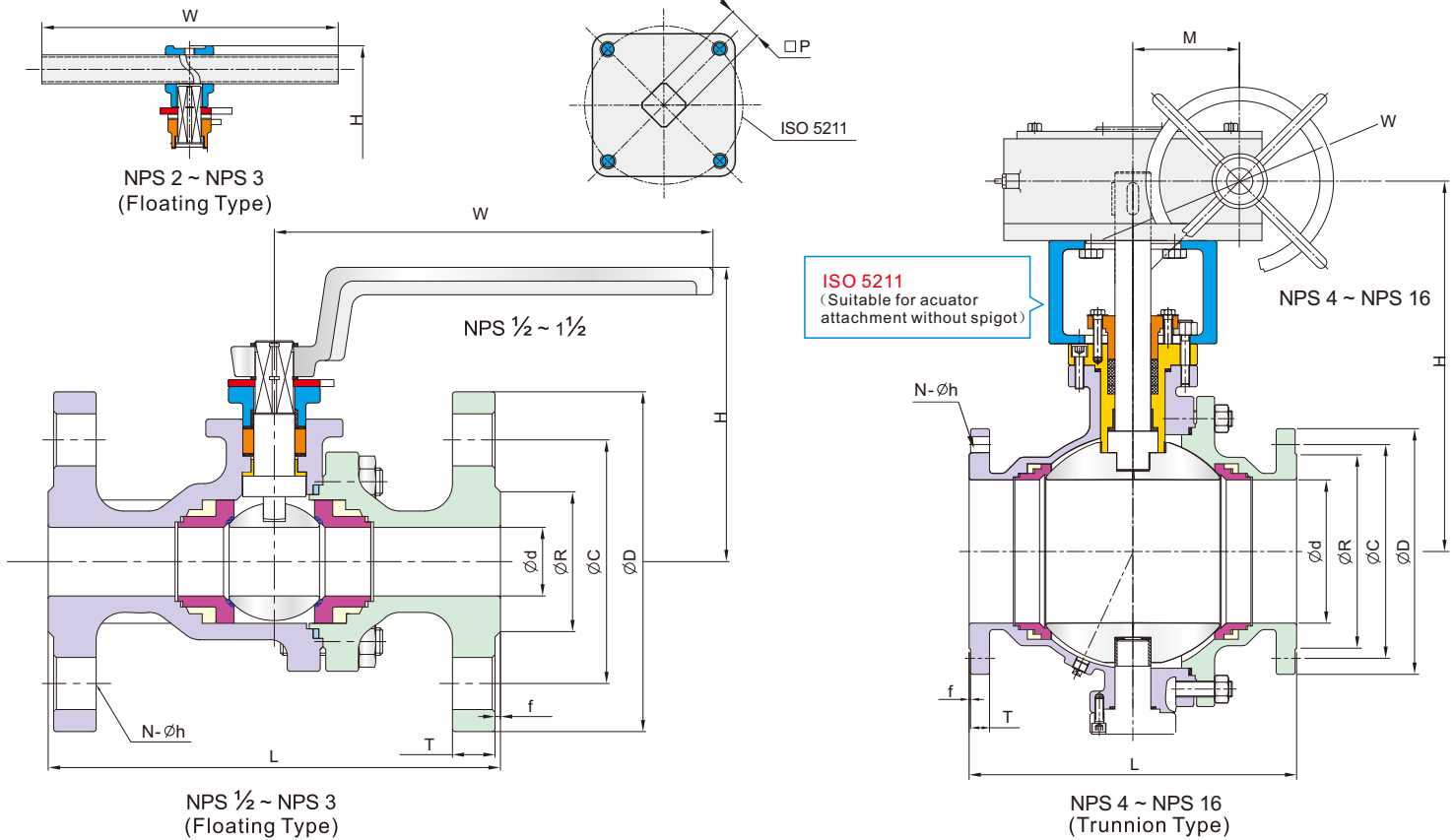

ASME Class 150

KV-M41, KV-M61

Unit: mm

NPS	d	L	R	C	D	f	T	N	h	H	W	M	P	ISO 5211 on Valve
1/2	15.0	108	34.9	60.3	90	2	8.0	4	16.0	82	130	—	9	F04
3/4	20.0	117	42.9	69.9	100	2	8.9	4	16.0	90	130	—	9	F04
1	25.0	127	50.8	79.4	110	2	9.6	4	16.0	107	160	—	11	F05
1 1/4	32.0	140	63.5	88.9	115	2	11.2	4	16.0	110	160	—	14	F07
1 1/2	38.0	165	73.0	98.4	125	2	12.7	4	16.0	130	265	—	14	F07
2	50.0	178	92.1	120.7	150	2	14.3	4	19.0	132	400	—	14	F07
2 1/2	63.5	190	104.8	139.7	180	2	15.9	4	19.0	195	400	—	17	F10
3	76.0	203	127.0	152.4	190	2	17.5	4	19.0	202	600	—	22	F10
4	100.0	229	157.2	190.5	230	2	22.3	8	19.0	320	360	81	22	F14
5	125.0	356	185.7	215.9	255	2	22.3	8	22.3	405	460	90	27	F16
6	150.0	394	215.9	241.3	280	2	23.9	8	22.3	426	600	126	27	F16
8	200.0	457	269.9	298.5	345	2	27.0	8	22.3	490	600	126	36	F16
10	252.0	533	323.8	362.0	405	2	28.6	12	25.4	510	600	126	46	F16
12	303.0	610	381.0	431.8	485	2	30.2	12	25.4	550	600	126	55	F25
14	334.0	686	412.8	476.3	535	2	33.4	12	28.6	643	600	138	—	F25
16	385.0	762	469.8	539.8	595	2	35.0	16	28.6	672	600	170	—	F25

ASME Class 300

KV-M42, KV-M62

Unit: mm

NPS	d	L	R	C	D	f	T	N	h	H	W	M	P	ISO 5211 on Valve
1/2	15.0	140	34.9	66.7	95.0	2	12.7	4	16.0	82	130	—	9	F04
3/4	20.0	152	42.9	82.6	115.0	2	14.3	4	19.0	90	130	—	9	F04
1	25.0	165	50.8	88.9	125.0	2	15.9	4	19.0	107	160	—	11	F05
1 1/4	32.0	178	63.5	98.4	135.0	2	17.1	4	19.0	110	160	—	14	F07
1 1/2	38.0	190	73.0	114.3	155.0	2	19.1	4	22.3	130	200	—	14	F07
2	50.0	216	92.1	127.0	165.0	2	20.7	8	19.0	132	400	—	14	F07
2 1/2	63.5	241	104.8	149.2	190.0	2	23.9	8	22.3	195	400	—	17	F10
3	76.0	282	127.0	168.3	210.0	2	27.0	8	22.3	202	600	—	22	F10
4	100.0	305	157.2	200.0	255.0	2	30.2	8	22.3	323	305	92	22	F14
5	125.0	381	185.7	235.0	280.0	2	33.4	8	22.3	351	406	105	27	F16
6	150.0	403	215.9	269.9	320.0	2	35.0	12	22.3	437	406	105	27	F16
8	200.0	502	269.9	330.2	380.0	2	39.7	12	25.4	502	508	120	36	F16
10	252.0	568	323.8	387.4	445.0	2	46.1	16	28.6	545	610	142	46	F16
12	303.0	648	381.0	450.8	520.0	2	49.3	16	31.8	615	610	172	55	F25
14	334.0	762	412.8	514.4	585.0	2	52.4	20	31.8	630	710	138	—	F25
16	385.0	838	469.9	571.5	650.0	2	55.6	20	35.1	680	710	138	—	F25

**ASME Class 600/900
Flanged Ends, Full Port**

KV-M43, KV-M45 (-29 °C ~ 200 °C)
KV-M63, KV-M65 (-29 °C ~ 400 °C) (Fire Safe Design)

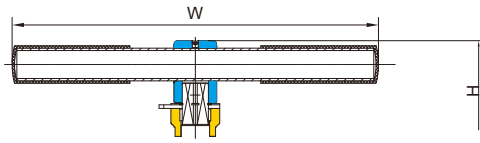

NPS 1 ~ NPS 3

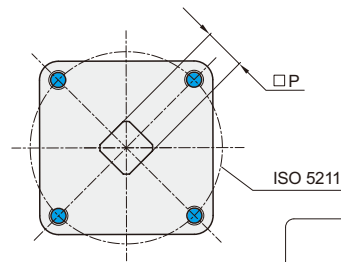

NPS 4 ~ NPS 16

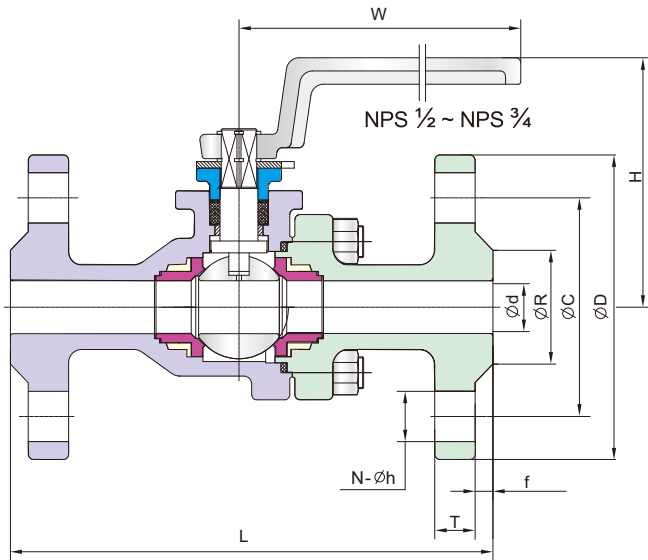

NPS 1/2 ~ NPS 3/4
(Floating Type)

ISO 5211
(Suitable for actuator attachment without spigot)

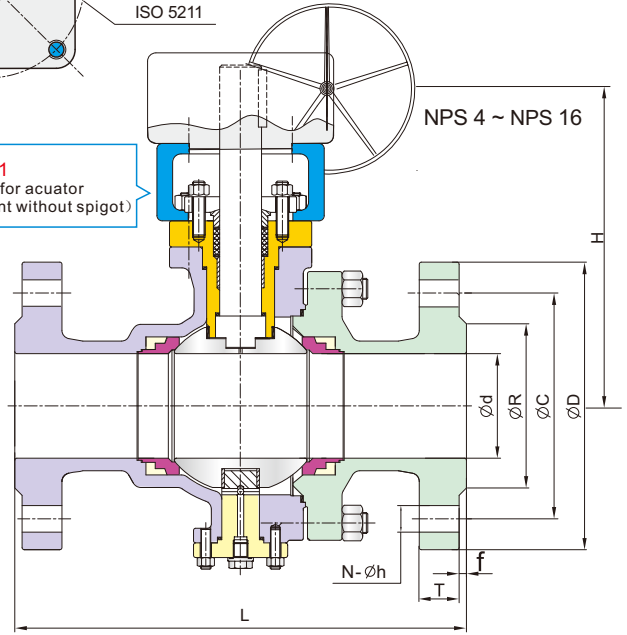

NPS 2 ~ NPS 16
(Trunnion Type)

ASME Class 600

KV-M43, KV-M63

Unit: mm

NPS	d	L	R	C	D	f	T	N	h	H	W	P	ISO 5211 on Valve
1/2	15	165	34.9	66.7	95.0	7	14.3	4	16.0	91	160	11	F05
3/4	20	190	42.9	82.6	115.0	7	15.9	4	19.0	96	160	11	F05
1	25	216	50.8	88.9	125.0	7	17.5	4	19.0	105	300	14	F07
1 1/2	38	241	73.0	114.3	155.0	7	22.3	4	22.3	155	300	17	F10
2	50	292	92.1	127.0	165.0	7	25.4	8	19.0	178	400	22	F10
2 1/2	65	330	104.8	149.2	190.0	7	28.6	8	22.3	230	800	27	F14
3	76	356	127.0	168.3	210.0	7	31.8	8	22.3	225	800	27	F14
4	100	432	157.2	215.9	275.0	7	38.1	8	25.4	300	—	34	F14
6	150	559	215.9	292.1	355.0	7	47.7	12	28.5	461	—	46	F16
8	202	660	269.9	349.2	420.0	7	55.6	12	31.8	515	—	55	F25
10	252	787	323.8	431.8	510.0	7	63.5	16	35.0	580	—	60	F25
12	303	838	381.0	489.0	560.0	7	66.7	20	35.0	770	—	—	F27
14	337	889	412.8	527.0	605.0	7	69.9	20	38.1	870	—	—	F32
16	387	991	469.9	603.2	685.0	7	76.2	20	41.3	1020	—	—	F35

ASME Class 900

KV-M45, KV-M65

Unit: mm

NPS	d	L	R	C	D	f	T	N	h	H	W	P	ISO 5211 on Valve
1/2	15	216	34.9	82.6	120	7	22.3	4	22.3	110.0	160	11	F05
3/4	20	229	42.9	88.9	130	7	25.4	4	22.3	101.0	160	11	F05
1	25	254	50.8	101.6	150	7	28.6	4	25.4	109.8	400	14	F07
1 1/2	38	305	73.0	123.8	180	7	31.8	4	28.5	184.6	400	17	F10
2	49	368	92.1	165.0	215	7	38.1	8	25.4	184.6	400	27	F12
2 1/2	65	419	104.8	190.5	245	7	41.3	8	28.5	263.0	800	27	F14
3	75	381	127.0	190.5	240	7	38.1	8	25.4	263.0	800	30	F14
4	100	457	157.2	235.0	290	7	44.5	8	31.8	350.0	—	34	F14
6	150	610	215.9	317.5	380	7	55.6	12	31.8	475.0	—	46	F16
8	202	737	269.9	393.5	470	7	63.5	12	38.1	563.0	—	55	F25
10	252	838	323.8	469.9	545	7	69.9	16	38.1	627.0	—	60	F25
12	303	965	381.0	533.4	610	7	79.4	20	38.1	770.0	—	—	F32
14	322	1029	412.8	558.8	640	7	85.8	20	41.3	870.0	—	—	F32
16	373	1130	469.9	616.0	705	7	88.9	20	44.5	1020.0	—	—	F35

**EN PN 10/16/25/40
2-PC Body, Flanged Ends, Full Port**

KV-M4J, KV-M4K, KV-M4M, KV-M4N (-29 °C ~ 200 °C)
KV-M6J, KV-M6K, KV-M6M, KV-M6N (-29 °C ~ 450 °C) (Fire Safe Type)

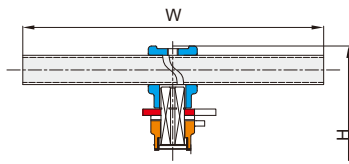

DN 50 ~ DN 80
(Floating Type)

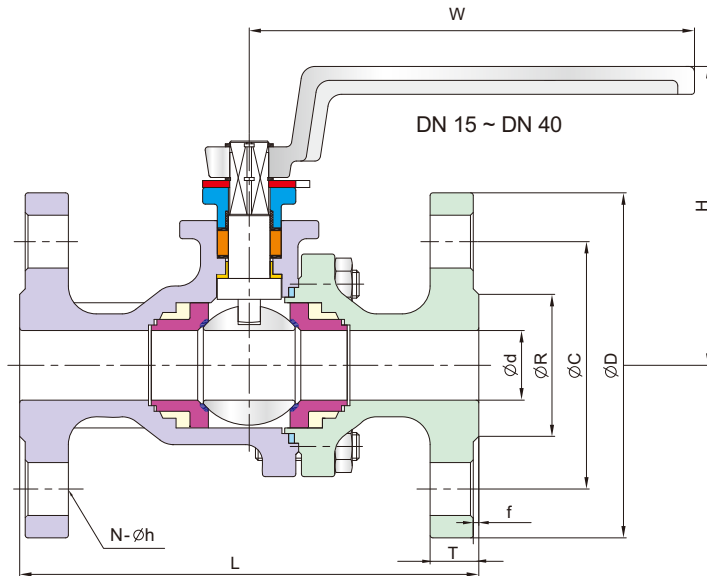
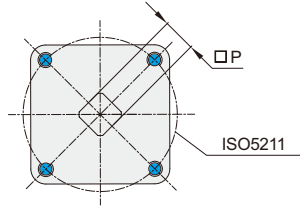

DN 15 ~ DN 80
(Floating Type)

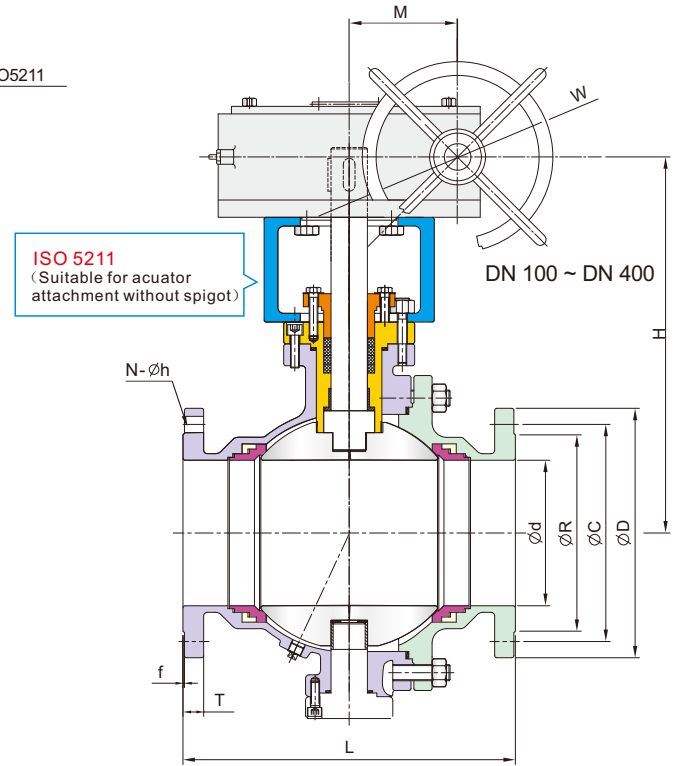

DN 100 ~ DN 400
(Trunnion Type)

EN PN 10/16/25/40 (EN 558)

Unit: mm

DN	PN	d	L	R	C	D	f	T	N	h	H	W	M	P	ISO 5211 on Valve	
15		15.0	130	45	65	95	2	16	4	14	82	130	—	9	F04	
20	10	20.0	150	58	75	105	2	18	4	14	90	130	—	9	F04	
25	16	25.0	160	68	85	115	2	18	4	14	107	160	—	11	F05	
32	25	32.0	180	78	100	140	2	18	4	18	110	160	—	14	F07	
40	40	38.0	200	88	110	150	2	18	4	18	130	200	—	14	F07	
50		50.0	230	102	125	165	2	20	4	18	132	400	—	14	F07	
65	10/16	63.5	290	122	145	185	2	18	4(a)	18	195	400	—	17	F10	
	22							8								
80	10/16	76.0	310	138	160	200	2	20	8	18	202	600	—	22	F10	
	24							8								
100	10/16	100.0	350	158	180	220	2	20	8	18	320	360	81	22	F14	
	162			190	235	24		22								
125	10/16	125.0	356	188	210	250	2	22	8	18	405	460	90	27	F16	
	400		220		270	26		26								
150	10/16	150.0	394	212	240	285	2	22	8	22	426	600	126	27	F16	
	480		218		250	300		28		26						
200	10	200.0	457	268	295	340	2	24	8	22	490	600	126	36	F16	
	16							30		26						
	25							34		30						
	40							34		30						
250	10	252.0	533	320	350	395	2	26	12	22	510	600	126	46	F16	
	16				355	405		26		26						
	25				370	425		32		30						
	40				345	385		450		38						33
300	10	303.0	610	370	400	445	2	26	12	22	550	600	126	55	F25	
	16				378	410		460		28						26
	25				395	430		485		34						30
	40				410	450		515		42						33

KV-M4J, KV-M6J — PN10 KV-M4M, KV-M6M — PN25
KV-M4K, KV-M6K — PN16 KV-M4N, KV-M6N — PN40

(a): 4 is factory standard for DN65 PN16 valve and 8 is optional.
DN15-DN100 PN10-PN40 EN 558 Series 1
DN125-DN300 PN10-PN16 EN 558 Series 12
DN125-DN300 PN25-PN40 EN 558 Series 1

JIS 10K/20K
2-PC Body, Flanged Ends, Full Port

KV-M4A, KV-M4C (-29 °C ~ 200 °C)
KV-M6A, KV-M6C (-29 °C ~ 450 °C) (Fire Safe Type)

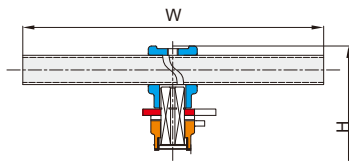

50A ~ 80A
(Floating Type)

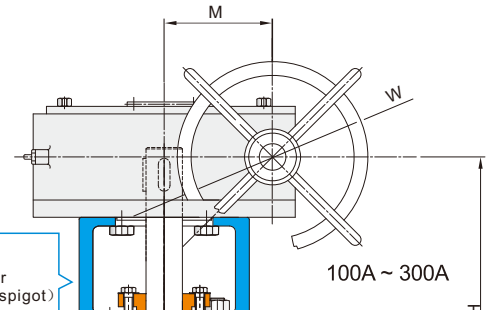
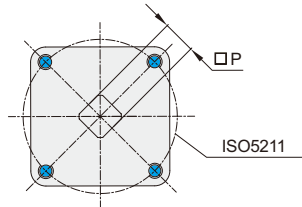

ISO 5211
(Suitable for actuator attachment without spigot)

100A ~ 300A

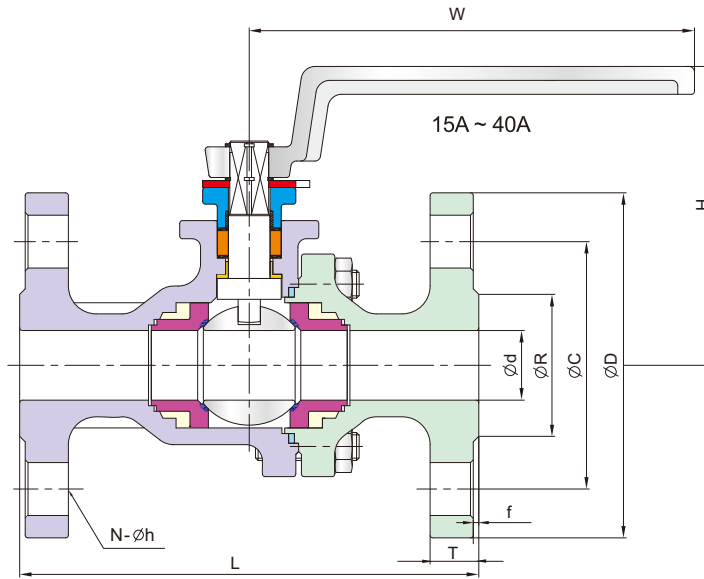

15A ~ 80A
(Floating Type)

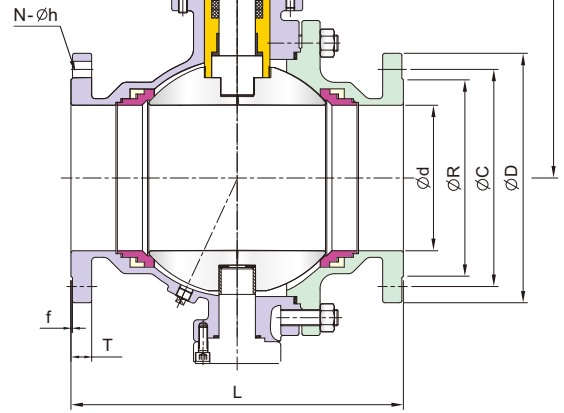

100A ~ 300A
(Trunnion Type)

JIS 10K

KV-M4A, KV-M6A

Unit: mm

Size	d	L	R	C	D	f	T	N	h	H	W	M	P	ISO 5211 on Valve
15A	15.0	108	51	70	95	1	12	4	15	82	130	—	9	F04
20A	20.0	117	56	75	100	1	14	4	15	90	130	—	9	F04
25A	25.0	127	67	90	125	1	14	4	19	107	160	—	11	F05
32A	32.0	140	76	100	135	2	16	4	19	110	160	—	14	F07
40A	38.0	165	81	105	140	2	16	4	19	130	265	—	14	F07
50A	50.0	178	96	120	155	2	16	4	19	132	400	—	14	F07
65A	63.5	190	116	140	175	2	18	4	19	195	400	—	17	F10
80A	76.0	203	126	150	185	2	18	4	19	202	600	—	22	F10
100A	100.0	229	151	175	210	2	18	8	19	320	360	81	22	F14
125A	125.0	356	182	210	250	2	20	8	23	405	460	90	27	F16
150A	150.0	394	212	240	280	2	22	8	23	426	600	126	27	F16
200A	200.0	457	262	290	330	2	22	12	23	490	600	126	36	F16
250A	252.0	533	324	355	400	2	24	12	25	510	600	126	46	F16
300A	303.0	610	368	400	445	3	24	16	25	550	600	126	55	F25

JIS 20K

KV-M4C, KV-M6C

Unit: mm

Size	d	L	R	C	D	f	T	N	h	H	W	M	P	ISO 5211 on Valve
15A	15.0	140	51	70	95	1	14	4	15	82	130	—	9	F04
20A	20.0	152	56	75	100	1	16	4	15	90	130	—	9	F04
25A	25.0	165	67	90	125	1	16	4	19	107	160	—	11	F05
32A	32.0	178	76	100	135	2	18	4	19	110	160	—	14	F07
40A	38.0	190	81	105	140	2	18	4	19	130	265	—	14	F07
50A	50.0	216	96	120	155	2	18	8	19	132	400	—	14	F07
65A	63.5	241	116	140	175	2	20	8	19	195	400	—	17	F10
80A	76.0	283	132	160	200	2	22	8	23	202	600	—	22	F10
100A	100.0	305	160	185	225	2	24	8	23	320	360	81	22	F14
125A	125.0	381	195	225	270	2	26	8	25	405	460	90	27	F16
150A	150.0	403	230	260	305	2	28	12	25	426	600	126	27	F16
200A	200.0	502	275	305	350	2	30	12	25	490	600	126	36	F16
250A	252.0	568	345	380	430	2	34	12	27	510	600	126	46	F16
300A	303.0	648	395	430	480	3	36	16	27	550	600	126	55	F25

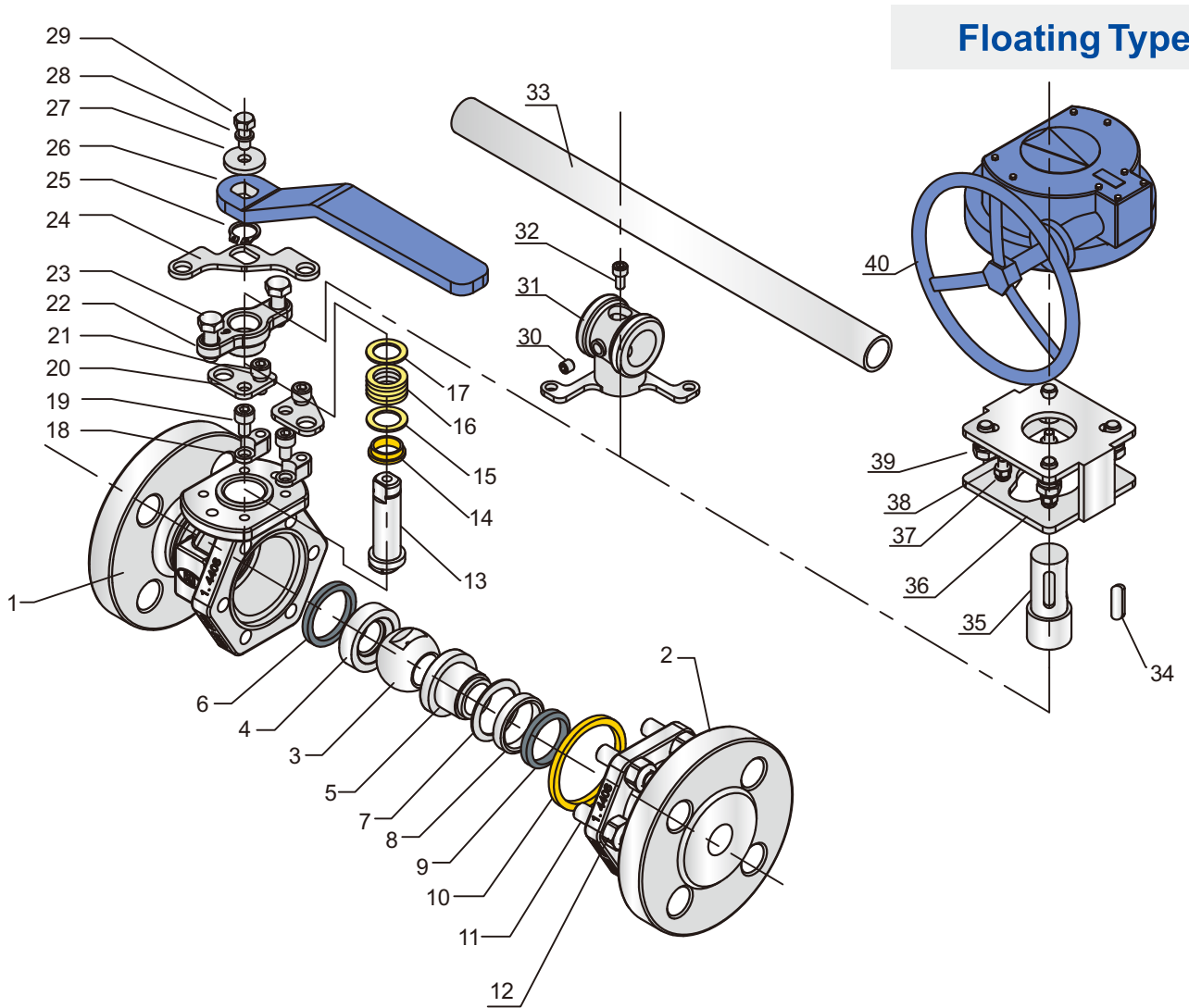

NO	PART NAME	MATERIALS		
1	Body	EN 10213-1.4408	EN 10213-1.4308	EN 10213-1.0619
2	Body end	EN 10213-1.4408	EN 10213-1.4308	EN 10213-1.0619
3	Ball	A182-F316+Cemented Carbide	A182-F304+Cemented Carbide	
4	Fixed seat	A182-F316+Cemented Carbide	A182-F304+Cemented Carbide	
5	Floating seat	A182-F316+Cemented Carbide	A182-F304+Cemented Carbide	
6	Sealing ring A	Graphite		
7	Belleville ring	INCONEL X-750 / SUS631		
8	Pressure ring	A182-F316	A182-F304	
9	Sealing ring B	Graphite		
10	Body gasket	316+Spiral wound+Graphite	304+Spiral wound+Graphite	
11	Bolting	A2-70		8.8
12	Nut	A2-70		8
13	Stem	ASTM A564-630		
14	Stem Sleeve	A439-D2		
15	Packing bushing	316	304	
16	Packing	Graphite		
17	Wear sheet	316	304	
18	Positioning sleeve	304		
19	Hexagon socket cap head screw	A2-70		
20	Positioning Pieces	304		
21	Hexagon socket cap head screw	A2-70		
22	Packing gland	A351-CF8M	A351-CF8	
23	Hexagon Bolt	A2-70		
24	Stopper locking	304		
25	Retainer ring	304		

Trunnion Type

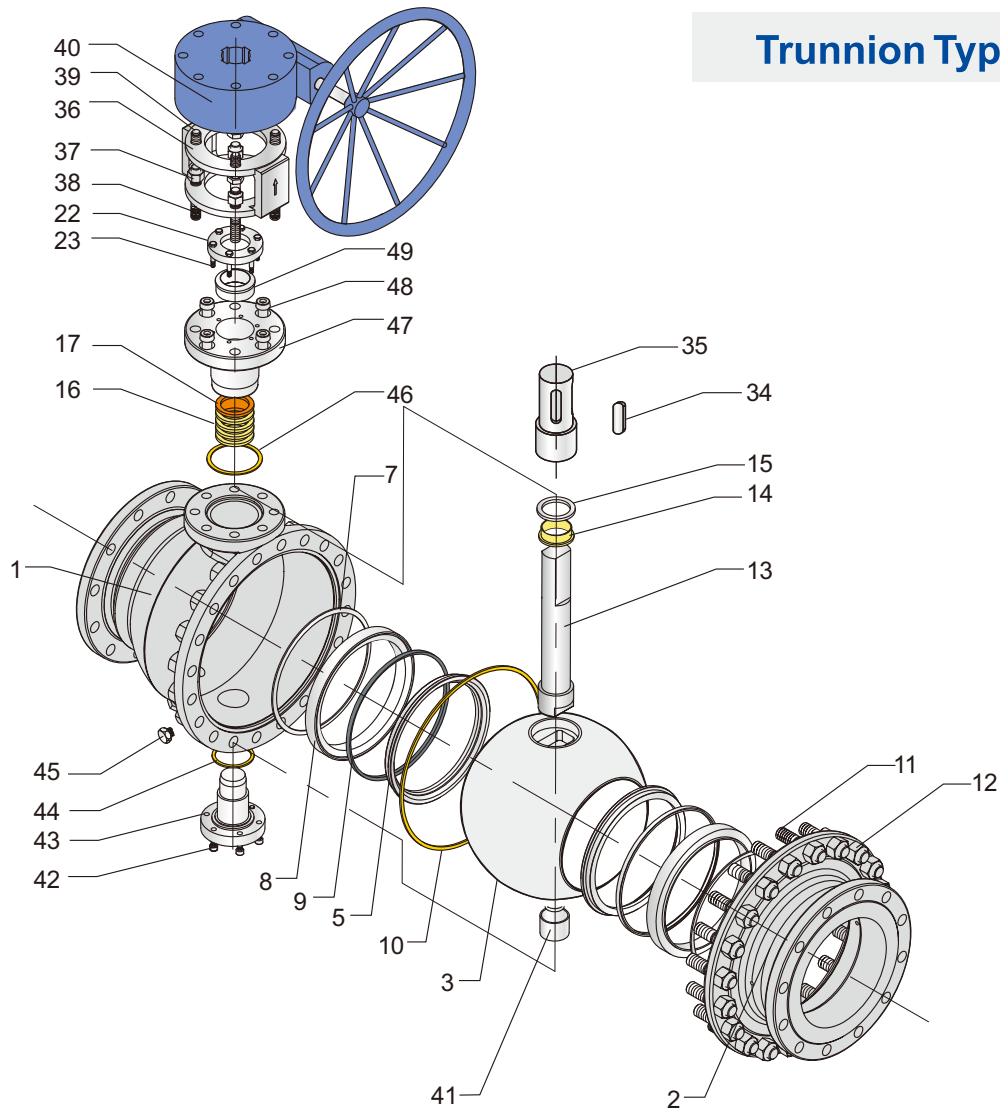

NO	PART NAME	MATERIALS		
26	Handle	A216-WCB		
27	Flat washers	304		
28	Spring washer	304		
29	Hexagon Bolt	A2-70		
30	Set screw	A2-70		
31	Handle connector	A351-CF8		
32	Screw	A2-70		
33	Steel tube handle	A53+Zn Plated		
34	Flat key	45#		
35	Coupling	ASTM A564-630		
36	Bracket	A216-WCB		
37	Nut	A2-70		8
38	Bolting	A2-70		8.8
39	Hexagon Bolt	A2-70		8.8
40	Worm gear	Assembly		
41	Bottom end cap sleeve	A439-D2		
42	Hexagon socket cap head screw	A2-70		8.8
43	Bottom end cap	ASTM A564-630		
44	Bottom end cap seal ring	316+Spiral wound+Graphite		304+Spiral wound+Graphite
45	Drain plug	316		304
46	Mid.Flange gasket	316+Spiral wound+Graphite		304+Spiral wound+Graphite
47	Mid.Flange	EN 10213-1.4408	EN 10213-1.4308	EN 10213-1.0619
48	Hexagon socket cap head screw	A2-70		8.8
49	Gland	316		304

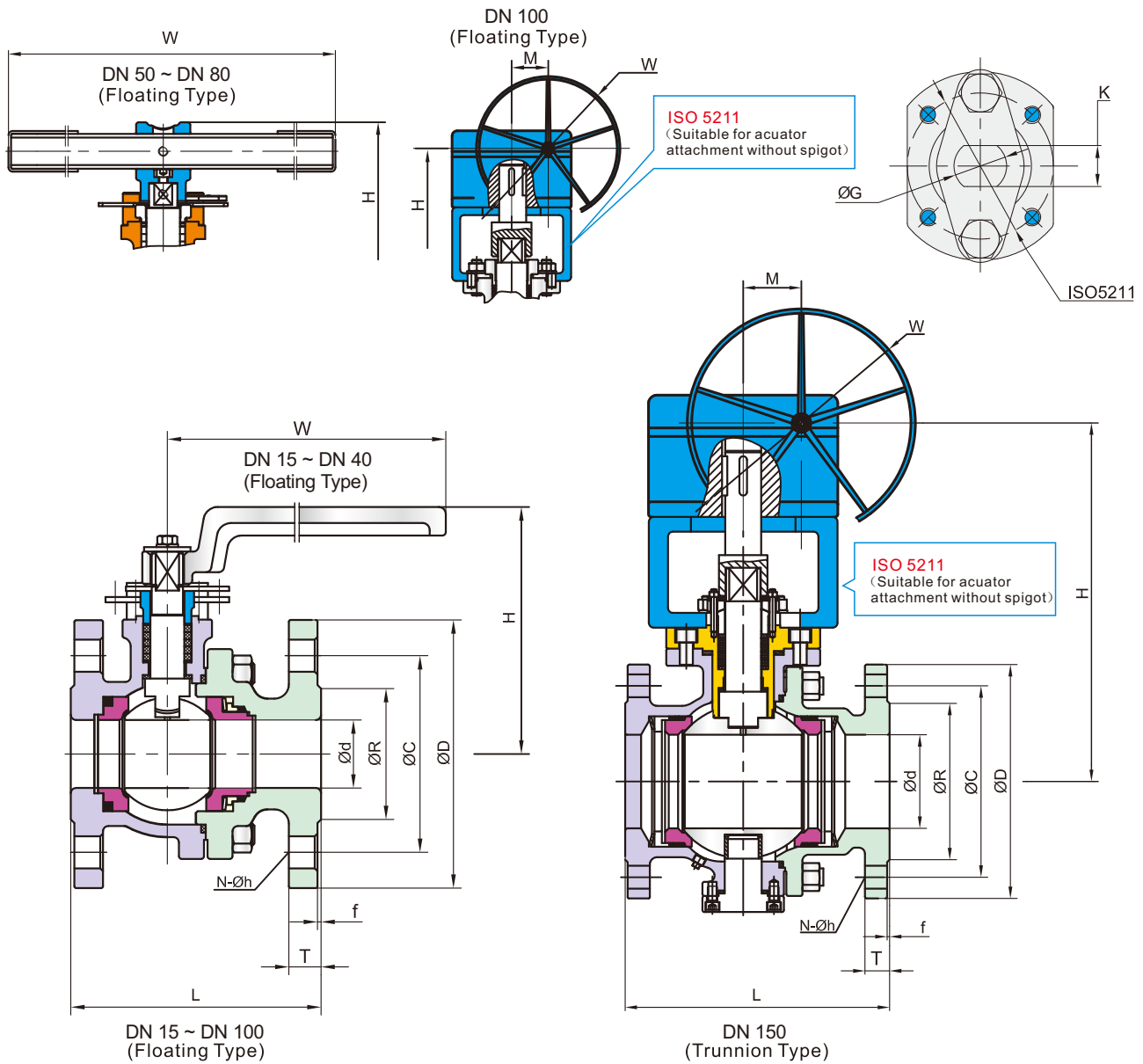

EN PN10/PN16/PN25/PN40 (EN 558 Series 27)

Unit: mm

DN	PN	d	L	R	C	D	f	T	N	h	H	W	M	G	K	ISO 5211
15	10	15	115	45	65	95	2	16	4	14	83	—	—	12	9	F03
20	16	20	120	58	75	105	2	18	4	14	87	—	—	12	9	F03
25	25	25	125	68	85	115	2	18	4	14	107	—	—	18	14	F05
40	40	38	140	88	110	150	3	18	4	18	122	—	—	18	14	F05
50	40	50	150	102	125	165	3	20	4	18	160	—	—	22	17	F07
80	10/16	76	180	138	160	200	3	20	8	18	210	—	—	28	22	F10
	24															
100	10/16	100	190	158	180	220	3	20	8	18	261	360	81	28	22	F10
	25/40			162	190	235	3	24		22						
150	10/16	150	350	212	240	285	3	22	8	22	429	600	126	48	36	F14
	25/40			218	250	300	3	28		8						

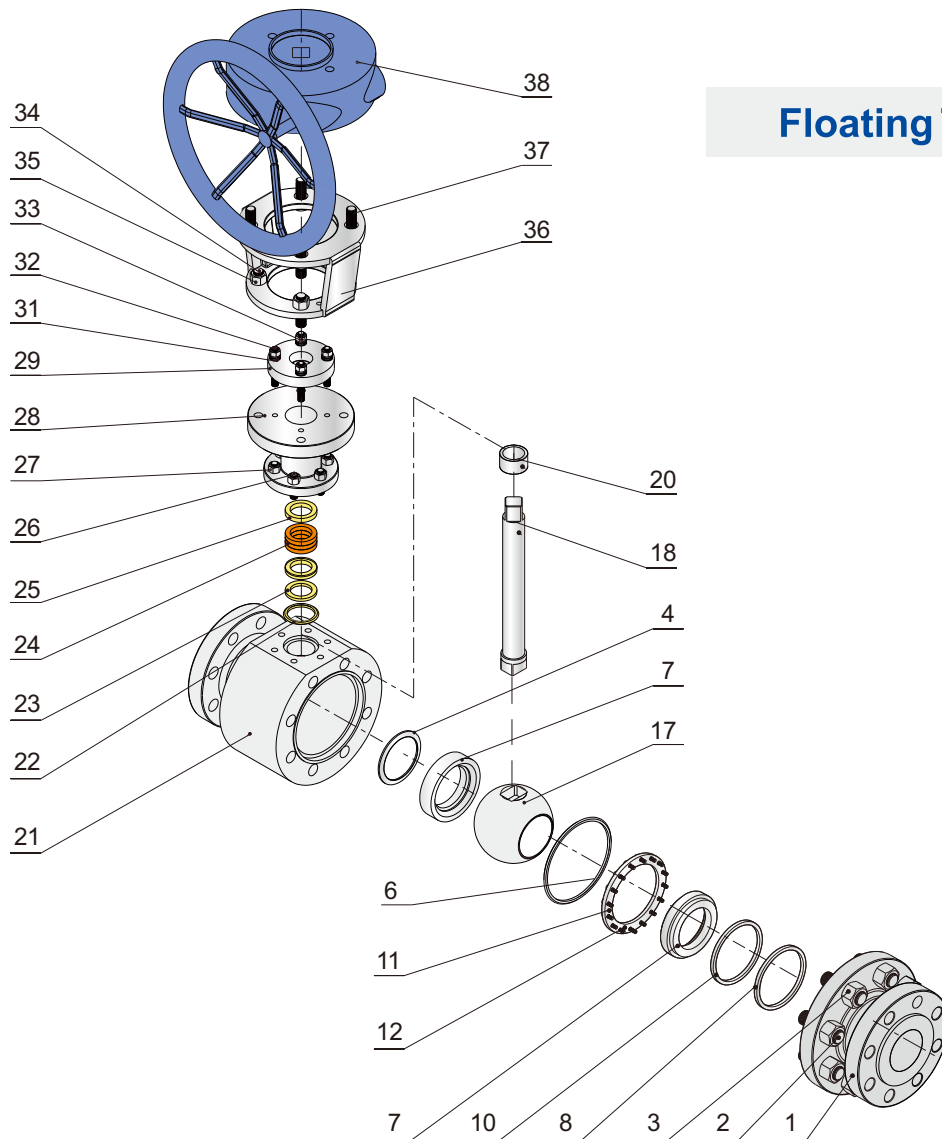

NO	PART NAME	MATERIALS	
1	End Cap	F316	F304
2	Body Stud		A193-B8
3	Hex Nut		A194-8
4	Seat Spring		Inconel x-750
5	Seat Spring		Inconel x-750
6	Gasket	316 SPIRAL WOUND+GRAPHITE	304 SPIRAL WOUND+GRAPHITE
7	Seats	F316+Ni60	F304+Ni60
8	Bearing Ring	F316	F304
9	Seat Housing	F316	F304
10	Seat Supporter		GRAPHITE
11	Seat Ring	F316	F304
12	Hex slotted Bolt		A193-B8
13	Stem		Gr660
14	Hex slotted Bolt		A193-B8
15	Stem Packing	316+ Grafoil	304+ Grafoil
16	Stem Sleeve		A439-D2
17	Ball	F316+Ni60	F304+Ni60
18	Stem		Gr.660
19	Pin		45# steel
20	Stem Bearing		A439-D2

* All valves with graphite stem packing, gasket, back-up seals & seal rings are inherently fire-safe

Trunnion Type

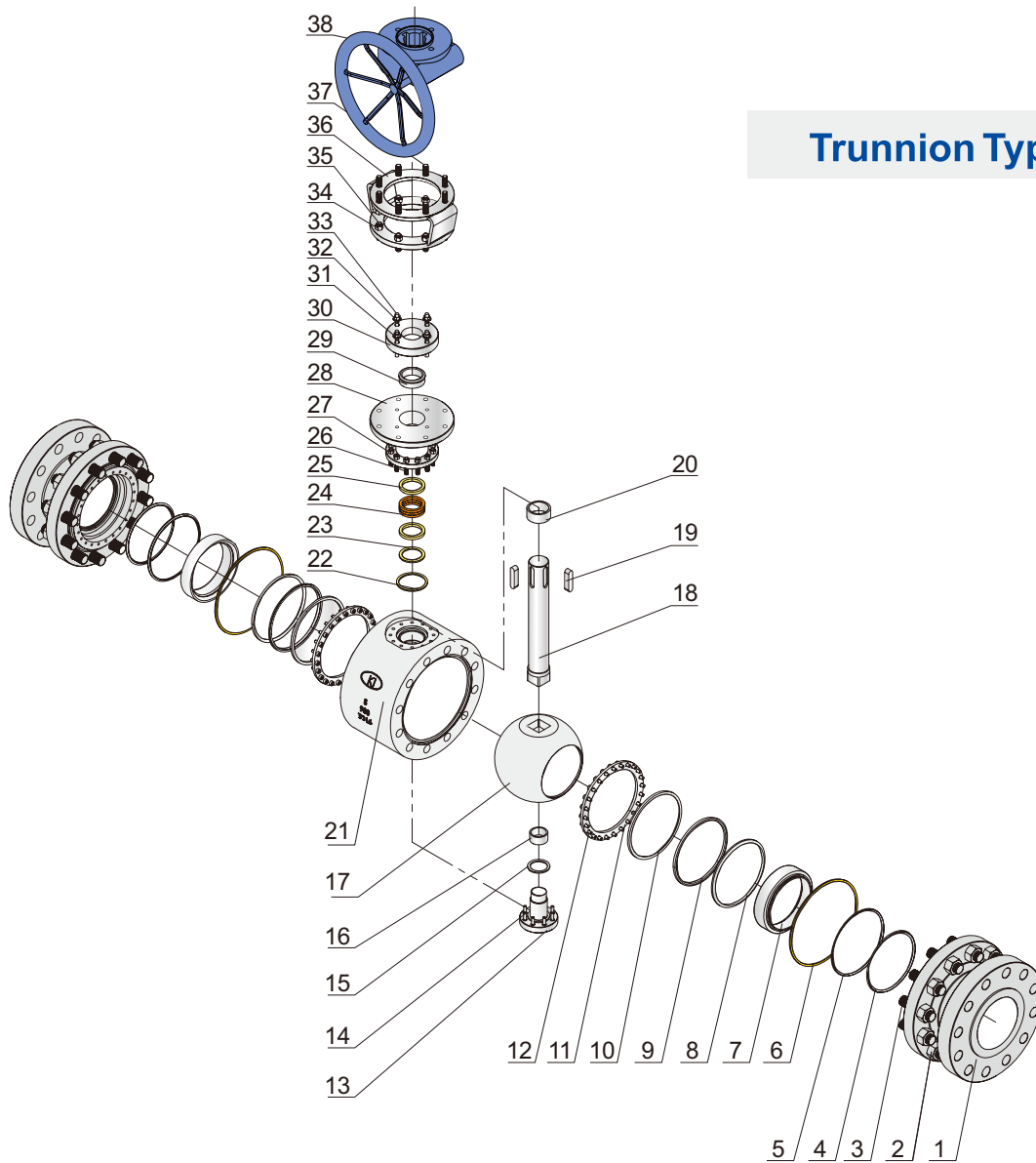

NO	PART NAME	MATERIALS	
21	Body	F316	F304
22	Mid. Flange	316 SPIRAL WOUND+GRAPHITE	304 SPIRAL WOUND+GRAPHITE
23	Stem washer	316	
24	Stem Packing	GRAPHITE	
25	Stem Packing	GRAPHITE	
26	Stud	A193-B8	
27	Hex Nut	A194-8	
28	Stop Flange	CF8	
29	Packing Protector	CF8	
30	Stop Gland	CF8	
31	Packing Spring	Inconel x-750	
32	Stud	A193-B8	
33	Hex Nut	A194-8	
34	Stud	A193-B8	
35	Hex Nut	A194-8	
36	Bracket	WCB	
37	Hex Bolt	A193-B8	
38	Worm Gear	Assembly	

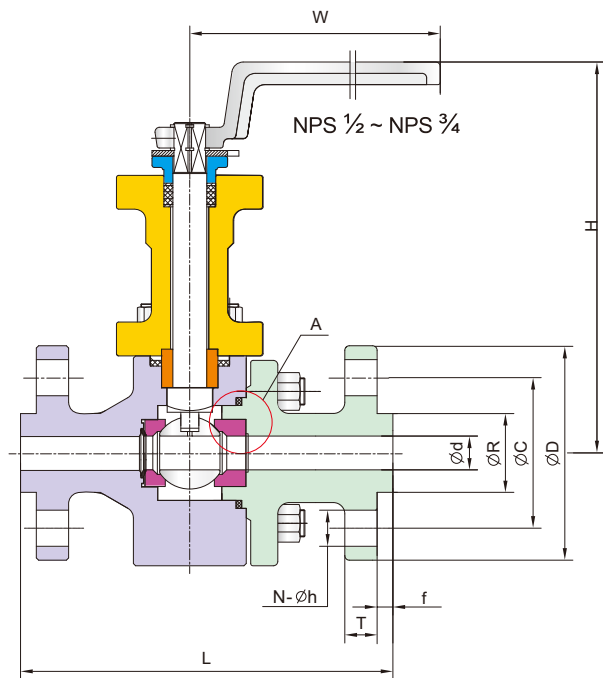
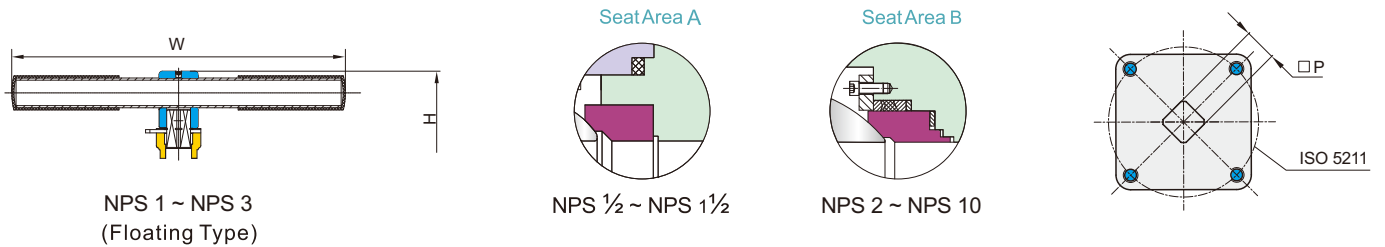

Floating Type
NPS 1/2 ~ NPS 3 (Class 600)
NPS 1/2 ~ NPS 1 1/2 (Class 900)

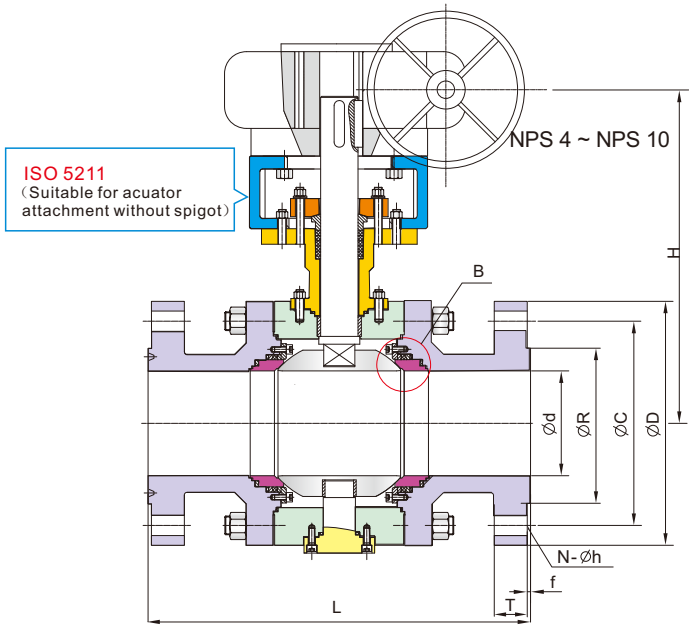

Trunnion Type
NPS 4 ~ NPS 10 (Class 600)
NPS 2 ~ NPS 10 (Class 900)

ASME Class 600

KV-M63-HF

Unit: mm

NPS	d	L	R	C	D	f	T	N	h	H	W	P	ISO 5211 on Valve
1/2	15	165	34.9	66.7	95.0	7	14.3	4	16.0	173.2	160	11	F05
3/4	20	190	42.9	82.6	115.0	7	15.9	4	19.0	175.0	160	11	F05
1	25	216	50.8	88.9	125.0	7	17.5	4	19.0	310.0	300	14	F07
1 1/2	38	241	73.0	114.3	155.5	7	22.3	4	22.3	330.0	400	17	F10
2	50	292	92.1	127.0	165.0	7	25.4	8	19.0	405.0	800	22	F14
2 1/2	65	330	104.8	149.2	190.0	7	28.6	8	22.3	456.0	800	27	F14
3	76	356	127.0	168.3	210.0	7	31.8	8	22.3	465.0	—	28	F14
4	100	432	157.2	215.9	275.0	7	38.1	8	25.4	530.0	—	34	F14
6	150	559	215.9	292.1	355.0	7	47.7	12	28.5	590.0	—	46	F16
8	200	660	269.9	349.2	420.0	7	55.6	12	31.8	645.0	—	55	F25
10	252	787	323.8	431.8	510.0	7	63.5	16	35.0	580.0	—	60	F25

ASME Class 900

KV-M65-HF

Unit: mm

NPS	d	L	R	C	D	f	T	N	h	H	W	P	ISO 5211 on Valve
1/2	15	216	35.0	82.6	120	7	22.3	4	22.3	173.2	160	11	F05
3/4	20	229	43.0	88.9	130	7	25.4	4	22.3	175.0	160	11	F05
1	25	254	50.8	101.6	150	7	28.6	4	25.4	310.0	400	14	F07
1 1/2	38	305	73.0	123.8	180	7	31.8	4	28.5	330.0	400	17	F10
2	49	368	92.1	165.0	216	7	38.1	8	25.4	405.0	400	27	F12
2 1/2	65	419	104.8	190.5	245	7	41.3	8	28.5	456.0	800	27	F14
3	75	381	127.0	190.5	240	7	38.1	8	25.4	465.0	800	30	F14
4	100	457	157.2	235.0	290	7	44.5	8	31.8	530.0	—	34	F14
6	150	610	216.0	317.5	380	7	55.6	12	31.8	590.0	—	46	F16
8	200	737	270.0	393.5	470	7	63.5	12	38.1	645.0	—	55	F25
10	252	838	324.0	469.9	545	7	69.9	16	38.1	580.0	—	60	F25

Metal Seat Ball Valves, Class 150/300/600/900

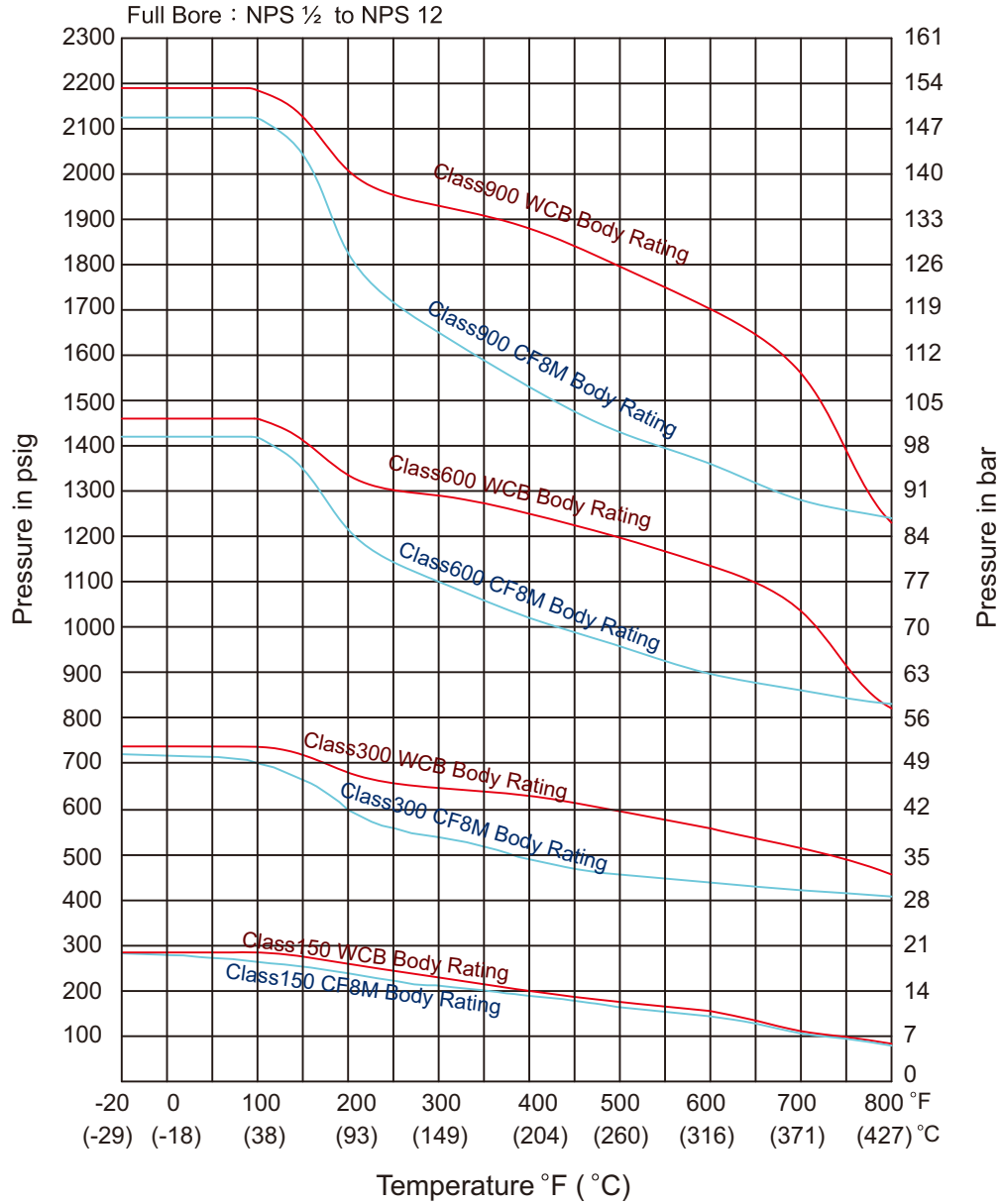

Metal Seat Ball Valves, PN 16/25/40

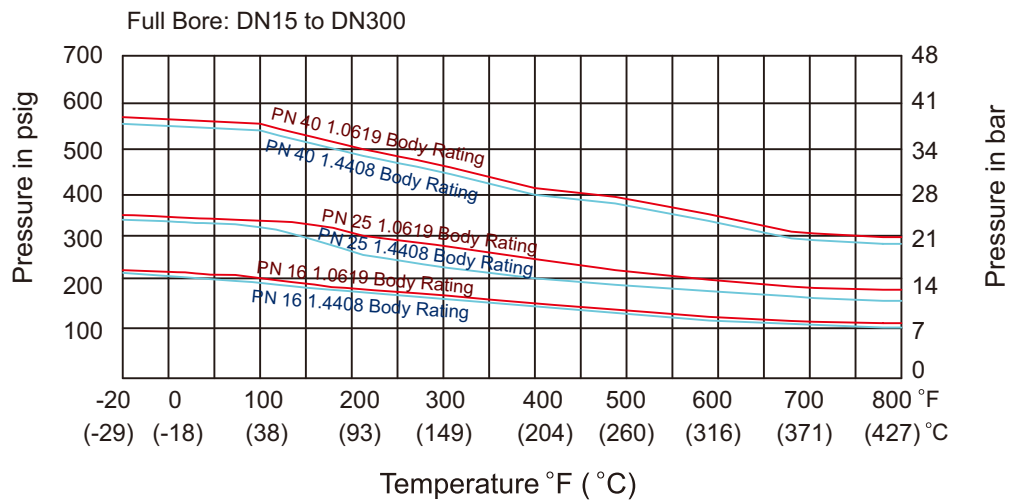

Torque Values

ASME Class 150 Ball Valve / KV-M41, KV-M61

EN PN10 ~ PN16 / KV-M4J, KV-M6J, KV-M4K, KV-M6K, KV-M64J-F27, KV-M64K-F27

JIS 10K / KV-M4A, KV-M6A

SIZE		1.0 MPa (10 bar)		1.6 MPa (16 bar)		2.0 MPa (20 bar)	
NPS	DN	N·m	In·lb	N·m	In·lb	N·m	In·lb
1/2	15	20	177	25	221	25	221
3/4	20	30	265	35	310	35	310
1	25	45	398	50	442	50	442
1 1/4	32	60	531	65	575	65	575
1 1/2	40	65	575	80	708	80	708
2	50	100	885	110	973	120	1062
2 1/2	65	190	1681	220	1947	230	2035
3	80	220	1947	240	2124	280	2478
4	100	340	3009	380	3363	430	3805
5	125	700	6195	850	7522	900	7965
6	150	1000	8850	1100	9735	1300	11504
8	200	1400	12389	1600	14159	1900	16814
10	250	1500	13274	2000	17699	2500	22124
12	300	2000	17699	2500	22124	3500	30974
14	350	3000	26549	4800	42478	5500	48673
16	400	3500	30974	5500	48673	7000	61947

ASME Class 300 Ball Valve / KV-M42, KV-M62

EN PN25 ~ PN40 / KV-M4M, KV-M6M, KV-M4N, KV-M6N, KV-M64M-F27, KV-M64N-F27

JIS 20K / KV-M4C, KV-M6C

SIZE		1.6 MPa (16 bar)		2.5 MPa (25 bar)		4.0 MPa (40 bar)		5.0 MPa (50 bar)	
NPS	DN	N·m	In·lb	N·m	In·lb	N·m	In·lb	N·m	In·lb
1/2	15	25	221	30	265	35	310	35	310
3/4	20	35	310	45	398	45	398	45	398
1	25	50	442	50	442	70	619	70	619
1 1/4	32	65	575	75	664	90	796	90	796
1 1/2	40	80	708	90	796	100	885	100	885
2	50	110	973	130	1150	170	1504	180	1593
2 1/2	65	220	1947	240	2124	300	2655	350	3097
3	80	240	2124	310	2743	350	3097	400	3540
4	100	380	3363	460	4071	550	4867	650	5752
5	125	850	7522	900	7965	1000	8850	1100	9735
6	150	1100	9735	1300	11504	1400	12389	1500	13274
8	200	1600	14159	2200	19469	2500	22124	2600	23009
10	250	2000	17699	3000	26549	3500	30974	4000	35398
12	300	2500	22124	3800	33628	4500	39823	5000	44248
14	350	4800	42478	6000	53098	6500	57522	7000	61947
16	400	5500	48673	8000	70797	9000	79646	10000	88496

Remarks on Torque Values:

- Safety factors are not built into the above Torque values.
For clear, non-viscous fluid multiply listed torque by 1.5.
For solid, slurry media multiply listed torque by 1.5 ~ 2.0.
- Other applications may affect above listed values.
- Consult factory for torque values for seat materials other than those listed.
- Handles are not recommended for valves larger than NPS 6. Gear operators or other actuators are recommended.
- The above Torque values are to be used as a guide only. Some variation is possible based on application.

Torque Values

ASME Class 600 Ball Valve / KV-M43, KV-M63

SIZE		5.0 MPa (50 bar)		6.4 MPa (64 bar)		10.0 MPa (100 bar)	
NPS	DN	N·m	In·lb	N·m	In·lb	N·m	In·lb
1/2	15	35	310	45	398	50	442
3/4	20	45	398	50	442	60	531
1	25	70	619	75	664	90	796
1 1/4	32	—	—	—	—	—	—
1 1/2	40	100	885	120	1062	150	1327
2	50	180	1593	230	2035	270	2389
2 1/2	65	350	3097	400	3540	500	4425
3	80	400	3540	650	5752	750	6637
4	100	650	5752	850	7522	1000	8850
5	125	—	—	—	—	—	—
6	150	1500	13274	1900	16814	2500	22124
8	200	2600	23009	4000	35398	5100	45133
10	250	4000	35398	6000	53098	7500	66372
12	300	5000	44248	8500	75222	12000	106195
14	350	7000	61947	11000	97346	18000	159293
16	400	10000	88496	15000	132744	23000	203541

Remarks on Torque Values:

- Safety factors are not built into the above Torque values.
For clear, non-viscous fluid multiply listed torque by 1.5.
For solid, slurry media multiply listed torque by 1.5 ~ 2.0.
- Other applications may affect above listed values.
- Consult factory for torque values for seat materials other than those listed.
- Handles are not recommended for valves larger than NPS 6. Gear operators or other actuators are recommended.
- The above Torque values are to be used as a guide only. Some variation is possible based on application.

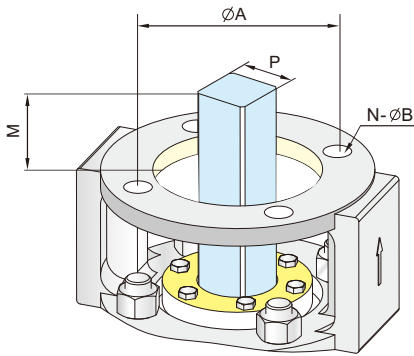

NPS 1/2 ~ NPS 12

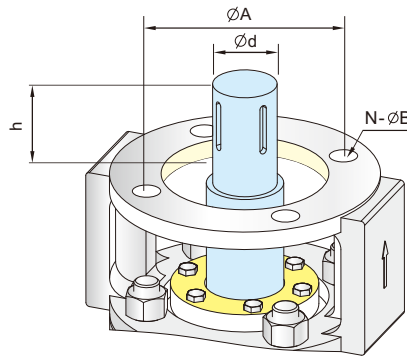

NPS 4 ~ NPS 12

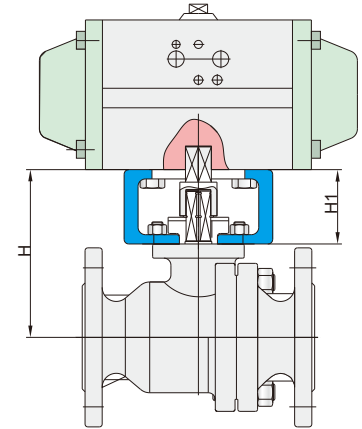

Connection Dimensions for Class 150 / PN 10 ~ PN 16 / JIS 10K

Unit: mm

NPS	DN	Ød	h	P	M	ØA	H	H1	N	ØB	ISO 5211 on Bracket
1/2	15	—	—	17	17	50 / 70	95	60	4	8 / 10	F05 / F07
3/4	20	—	—	17	17	50 / 70	100	60	4	8 / 10	F05 / F07
1	25	—	—	22	22	50 / 70	112	60	4	8 / 10	F05 / F07
1 1/4	32	—	—	22	22	70 / 102	128	62	4	10 / 12	F07 / F10
1 1/2	40	—	—	22	22	70 / 102	128	62	4	10 / 12	F07 / F10
2	50	—	—	22	22	70 / 102	138	62	4	10 / 12	F07 / F10
2 1/2	65	—	—	27	27	125 / 140	178	76	4	14 / 18	F12 / F14
3	80	—	—	27	27	125 / 140	184	76	4	14 / 18	F12 / F14
4	100	40	75	36	36	140	270	80	4	18	F14
5	125	40	89	46	46	165	350	129	4	22	F16
6	150	40	89	46	46	165	366	129	4	22	F16
8	200	50	92	46	46	165	429	144	4	22	F16
10	250	60	89	55	55	254	450	144	8	18	F25
12	300	72	106	55	55	254	481	140	8	18	F25

Connection Dimensions for Class 300 / PN 25 ~ PN 40 / JIS 20K

Unit: mm

NPS	DN	Ød	h	P	M	ØA	H	H1	N	ØB	ISO 5211 on Bracket
1/2	15	—	—	17	17	50 / 70	95	60	4	8 / 10	F05 / F07
3/4	20	—	—	17	17	50 / 70	100	60	4	8 / 10	F05 / F07
1	25	—	—	22	22	50 / 70	112	60	4	8 / 10	F05 / F07
1 1/4	32	—	—	22	22	70 / 102	128	62	4	10 / 12	F07 / F10
1 1/2	40	—	—	22	22	70 / 102	128	62	4	10 / 12	F07 / F10
2	50	—	—	22	22	70 / 102	138	62	4	10 / 12	F07 / F10
2 1/2	65	—	—	27	27	125 / 140	178	76	4	14 / 18	F12 / F14
3	80	—	—	27	27	125 / 140	184	76	4	14 / 18	F12 / F14
4	100	40	75	36	36	140	270	80	4	18	F14
5	125	40	89	46	46	165	350	129	4	22	F16
6	150	40	89	46	46	165	366	129	4	22	F16
8	200	50	92	46	46	165	429	144	4	22	F16
10	250	60	89	55	55	254	450	144	8	18	F25
12	300	72	106	55	55	254	481	140	8	18	F25

Note : the P value is connected with a transmission shaft head size

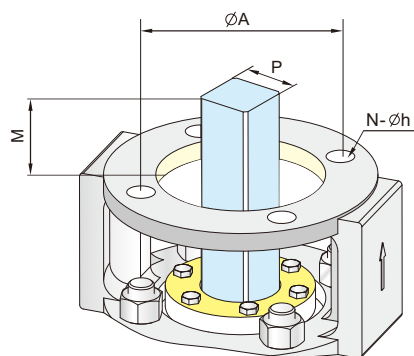

NPS 1/2 ~ NPS 10

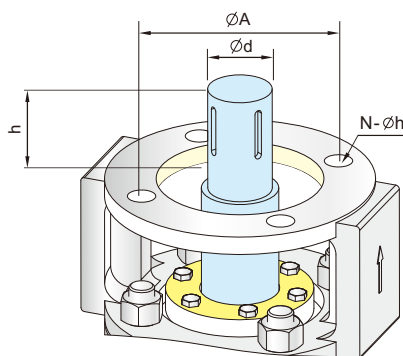

NPS 2 ~ NPS 10

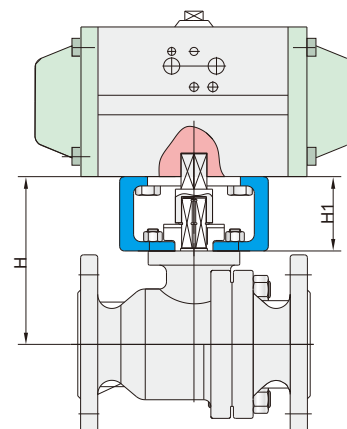

Connection Dimensions for Class 600 / PN 100

Unit: mm

NPS	DN	Ød	h	P	M	ØA	H	H1	N	ØB	ISO 5211 on Bracket
1/2	15	—	—	22	22	70	183.0	60	4	10	F07
3/4	20	—	—	22	22	70	183.0	60	4	10	F07
1	25	—	—	27	27	102	220.0	60	4	12	F10
1 1/2	40	—	—	27	27	102	264.0	70	4	12	F12
2	50	—	—	36	36	140	284.0	76	4	18	F14
2 1/2	65	—	—	36	36	140	337.0	110	4	18	F14
3	80	—	—	36	36	165	343.0	110	4	22	F16
4	100	—	—	46	46	165	380.0	125	4	22	F16
6	150	50	90	46	46	165	472.0	144	4	22	F16
8	200	60	115	55	55	254	515.0	140	8	18	F25
10	250	72	115	55	55	254	567.0	140	8	18	F25

Connection Dimensions for Class 900 / PN 150

Unit: mm

NPS	DN	Ød	h	P	M	ØA	H	H1	N	ØB	ISO 5211 on Bracket
1/2	15	—	—	17	17	70	183.0	60	4	10	F07
3/4	20	—	—	17	17	70	183.0	60	4	10	F07
1	25	—	—	27	27	102	220.0	60	4	12	F10
1 1/2	40	—	—	27	27	102	264.0	70	4	12	F12
2	50	—	—	36	36	140	284.0	76	4	18	F14
2 1/2	65	—	—	36	36	140	337.0	110	4	18	F14
3	80	—	—	46	46	165	343.0	110	4	22	F16
4	100	—	—	46	46	165	380.0	125	4	22	F16
6	150	60	90	46	46	165	427.0	144	4	22	F16
8	200	72	115	55	55	254	515.0	140	8	18	F25
10	250	85	115	55	55	254	567.0	140	8	18	F25

Note : the P value is connected with a transmission shaft head size

KI **Kingdom** FLOW CONTROL CO., LTD.

Headquarters (International Dept.)

16F, 120, Jhongjheng 1st Rd., Kaohsiung 80284, Taiwan
Tel: +886-7-7713121 Fax: +886-7-7235165
E-mail: sales@kifc.com

Zhongshan Factory

23-1, Nan-hou West Rd., Nan-tou Zhongshan City, Guangdong 528427, China
Tel: +86-760-23132179 23116839 Fax: +86-760-23110582

Fujian Factory

No. 1 Hengshan Industrial Road, Huangtian Town, Gutian County,
Fujian 352251, China
Tel: +86-593-3761598 Fax: +86-593-3762688

Vietnam Factory

Lot C-6A-CN, C-5A-CN, My Phuoc 2 Industrial Park, Ben Cat District,
Binh Duong Province, Vietnam
Tel: +84-2743-559866



KI-MS 202203 (2.9)
©2022 Kingdom Flow Control Co., Ltd.
All rights reserved.

The contents of this publication are presented for information purpose only, and while effort has been made to ensure their accuracy, they are not to be construed as warranties or guarantees, expressed or implied, regarding the products or services described herein or their use or applicability. All sales are governed by our terms and conditions. We reserve the right to modify or improve the designs or specifications of our products at any time without notice. Always verify that you have the most recent product specifications or other documentation prior to the installation of these products.