

## 3-Pce Screwed Full Bore Ball Valve lever operated

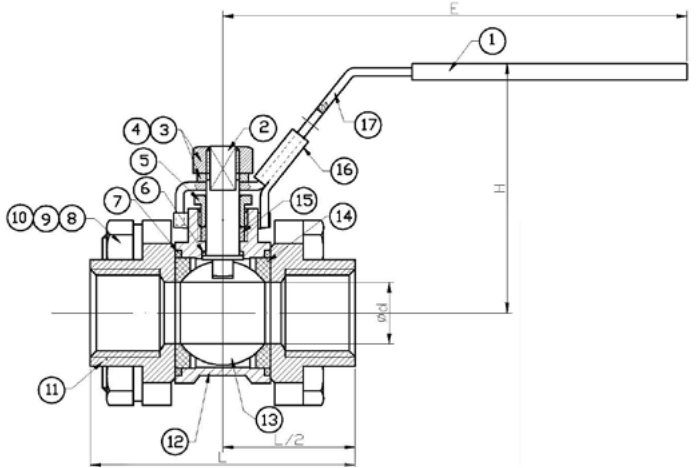

- ASTM A351 CF8M 316 Stainless Steel construction, 316 Trim.
- PTFE Seats and Seals. Adjustable gland. Slide type Locking Lever.
- 1000 psi/g Pressure rated (1/4" - 2") 600 psi/g Pressure rated (2.5" - 4").
- -20 / + 180 Deg C Temperature rated.
- BSP and NPT End Connections. Pressure balance hole in Ball Slot.
- CE marked (sizes 1.1/4" upward) in accordance with the PED 2014/68/EU

A good quality, general purpose ball valve suitable for most Liquid and Gaseous duties. Ball can be drilled for upstream vent applications such as bleach and peroxide duties.

**15% Glass R-PTFE Seal Kits available for elevated temperature duties.**

**EN10204 3.1 material Test Certificates available**

**Test standard – API 598**

**BSP Ends - ISO 7-1**

**NPT Ends - ASME B1.20.1**

**Available size range: 1/4" - 4"**

Item	Part	Material	Qty.
1	Handle Cover	PLASTIC	1
2	Stem	316	1
3	Hand Washer	304	1
4	Hand Nut	304	1
5	Gland	304	1
6	Thrust Washer	PTFE	1
7	End Seal	PTFE	2
8	Bolt	304	4
9	Bolt Nut	304	4
10	Bolt Washer	304	4
11	End Cap	CF8M	2
12	Body	CF8M	1
13	Ball	CF8M	1
14	Ball Seat	PTFE	2
15	Stem Packing	PTFE	1
16	Locking Device	304	1
17	Handle	304	1

SIZE	d	L	H	E
1/4"	9.2	59	52	108
3/8"	12.8	60	52	108
1/2"	15	65.5	63	113
3/4"	20	76.5	68	113
1"	25	86.2	79	135
1-1/4"	32	103.1	88	135
1-1/2"	38	118	97	160
2"	50	131.5	108	160
2-1/2"	65	164.6	128	230
3"	80	182.7	140	230
4"	100	217.7	172	335

**Pressure-Temp. Rating**

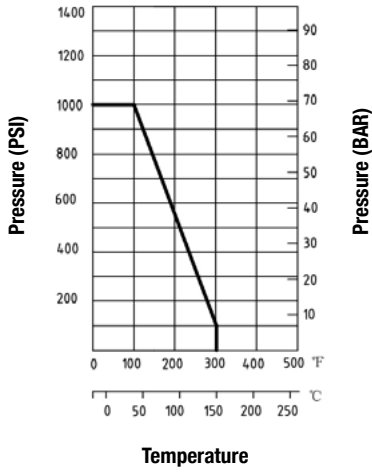

**1/4" - 2"**

**Pressure-Temp. Rating**

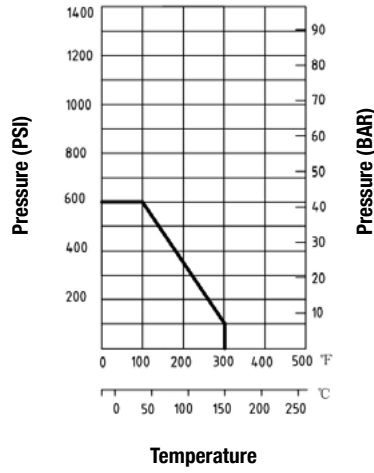

**2 1/2" - 4"**

**End Cap Dimensions**

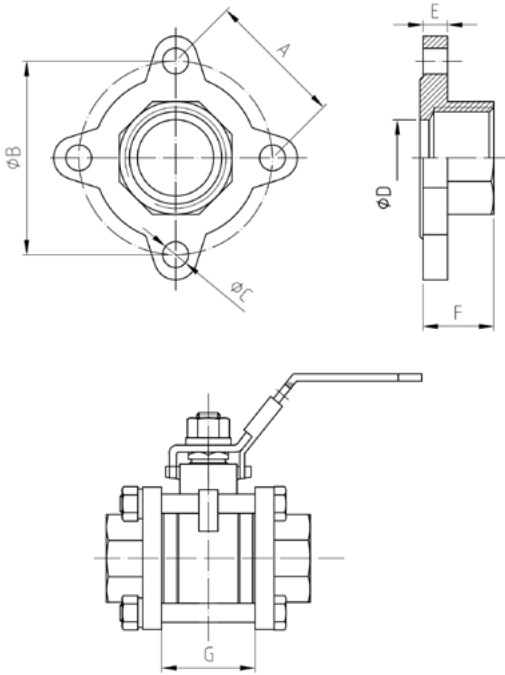

SIZE	A	ø B	ø C	ø D	E	F	G
1/4"	24.8	35	7	9.2	6	18.5	20
3/8"	27.2	38.5	6.5	12.8	6	18	22
1/2"	31.8	45	8.5	15	7	20.1	23.3
3/4"	40	56.7	8.5	20	7	21.85	30.8
1"	45	63.5	8.5	25	8	23.2	37.8
1-1/4"	53	75	8.5	32	9.5	27.5	47
1-1/2"	63.3	89.5	12.5	38	10.5	29.5	57
2"	78.9	111.5	12.5	50	11.5	30.8	68
2-1/2"	98.3	139	15	65	12	37.8	88.1
3"	116.7	165	17	80	14	40.8	100.2
4"	100.3	200.5	19	100	18	48.8	119.1