

## 2-Pce Standard Bore Direct Mount High Pressure Ball Valve

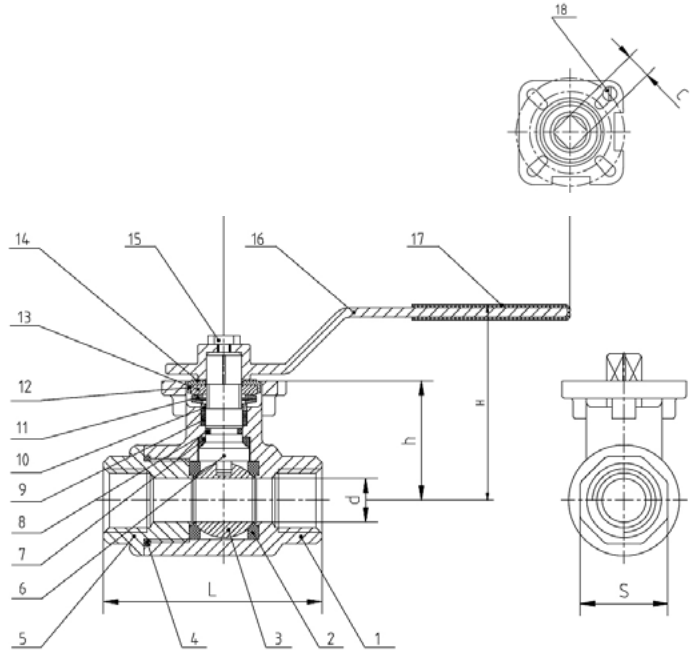

•ASTM A351 CF8M 316 Stainless Steel construction, 316 Trim.

•Delrin (POM) Ball Seats and R-PTFE Seals. 3000 psi/g Pressure rated.

•-25 / + 80 Deg C Temperature rated.

•Unsuitable for Oxygen duty and elevated temperatures.

•ISO 5211 Direct Mounting Pad with Lockable Lever.

•BSPP (ISO 228-1) and NPT (ASME B1.20.1) End Connections.

A good quality, high cycle life ball valve suitable for most High Pressure Liquid and Gaseous duties. Must NOT be used on Oxygen service. Full material Test Certificates available EN10204 3.1

**Test standard – API 598**

**NPT Ends - ASME B1.20.1**

**BSPP Ends - ISO 228-1**

**Available size range: 1/4" - 2"**

| Item | Part              | Material    | Qty. |
|------|-------------------|-------------|------|
| 1    | Body              | CF8M        | 1    |
| 2    | Ball Seat         | DELIN       | 2    |
| 3    | Ball              | SS316       | 1    |
| 4    | Body Gasket       | R-PTFE(15%) | 1    |
| 5    | Cap               | CF8M        | 1    |
| 6    | Stem              | SS316       | 1    |
| 7    | Thrust Washer     | R-PTFE(15%) | 1    |
| 8    | O-Ring            | VITON       | 1    |
| 9    | Stem Packing      | R-PTFE(15%) | 1    |
| 10   | Stem Ring         | SS316       | 1    |
| 11   | Belleville Washer | SS301       | 2    |
| 12   | Nut Stopper       | SS304       | 1    |
| 13   | Nut               | SS304       | 1    |
| 14   | Plate Washer      | SS304       | 1    |
| 15   | Bolt              | SS304       | 1    |
| 16   | Handle            | CF8         | 1    |
| 17   | Plastic Cover     | PLASTIC     | 1    |
| 18   | Stop Pin          | SS304       | 1    |

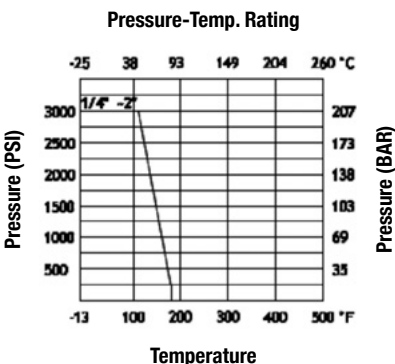

| SIZE   | d    | L   | H   | W   | C  | S  | ISO5211 | Kgs  |
|--------|------|-----|-----|-----|----|----|---------|------|
| 1/4"   | 9.7  | 75  | 70  | 133 | 9  | 26 | F03/F04 | 0.80 |
| 3/8"   | 9.7  | 75  | 70  | 133 | 9  | 26 | F03/F04 | 0.78 |
| 1/2"   | 12.7 | 75  | 70  | 133 | 9  | 30 | F03/F04 | 0.76 |
| 3/4"   | 17.5 | 81  | 72  | 133 | 9  | 38 | F03/F04 | 1.00 |
| 1"     | 22.1 | 91  | 83  | 165 | 11 | 46 | F04/F05 | 1.56 |
| 1-1/4" | 29   | 110 | 90  | 165 | 11 | 59 | F04/F05 | 2.44 |
| 1-1/2" | 34.7 | 121 | 114 | 210 | 14 | 66 | F05/F07 | 3.62 |
| 2"     | 34.7 | 145 | 114 | 210 | 14 | 75 | F05/F07 | 4.76 |